

# Specification sheet

# XF 310

FT 4X2 Tractor, Electric



## ENGINES

XD Electric 270 PACCAR EX-D2 (270 kW /	315 kWh   420 kWh   525 kWh)
XD Electric 310 PACCAR EX-D2 (310kW /	420 kWh   525 kWh)
XD Electric 350 PACCAR EX-D2 (350kW /	420 kWh   525 kWh)

## GVM<sup>1)</sup>

18000 kg

Max. front 8000 kg

Max. rear 11500 kg

## GCM<sup>2)</sup>

42000 kg

## CAB EXTERIOR

Luxurious Sleeper Cab with unrivalled aerodynamics for fuel efficient driving and low CO2 emissions. The huge and deep frontscreen, curved at the sides combined with large side windows offer an unsurpassed direct view for the driver, to enhance road safety. The cab interior is extremely comfortable for driving, living and sleeping with unprecedented spaciousness and practical layout. Cab length: 2360 mm; cab width: 2500 mm.; Cab suspension mechanical; LED head lights; Front view mirror.

### Optional

<b>06244</b> Sleeper High Cab	<b>00949</b> LED Skylights; aux. LED lights on cab rf, prepared
<b>02889</b> Chassis front execution: no bottom plate	<b>01925</b> Two LED work lamps for cab rear wall
<b>02952</b> Chassis front execution: bottom plate aero	<b>01891</b> Hazard beacons on cab front, prepared
<b>07586</b> Chassis front execution: robust	<b>06629</b> Two hazard beacon lights
<b>03358</b> External sun visor	<b>03231</b> Front windscreen
<b>06790</b> Aluminium ladder 1-piece	<b>03317</b> Rear window: double glass
<b>06791</b> Aluminium ladder 2-piece	<b>07343</b> Kerb view window co-driver door
<b>03922</b> Fog lights front	<b>01550</b> No front view mirror
<b>00936</b> Auxiliary LED lights on cab roof, prepared	<b>01362</b> DAF Digital Vision System
<b>01836</b> LED Skylights	<b>01913</b> DAF Corner View

## AERODYNAMICS

### Optional

<b>00010</b> Adj. roof air deflector short Sleeper High Cab	<b>00118</b> Adj. roof air deflector for Sleeper Cab
<b>01904</b> Adj. rf air defl. long low >4m(!) XF Sl. High Cab	<b>00021</b> Adj. roof air deflector long low Sleeper High Cab
<b>00138</b> Adj. rf air defl. long mid >4m(!) Sleeper High Cab	<b>04906</b> Side collars, one side hinged
<b>01552</b> Adj. roof air defl. long high >4m(!) Sleeper High	<b>03074</b> Side collars, both sides hinged

## COLOURS

Cab colour E1980 Crystal White; Chassis colour grey.; Colour of bumper: Crystal White.

## CAB INTERIOR

Cab interior trim colour: Luxury; Dashboard finish: Vision; Cab interior decoration: Hexagon; Driver seat: Comfort Air; No arm rest driver seat; Co-driver seat: cinema with fabric cover; Dashboard table; Storage compartment in centre; Automatic Temperature Control and airc; Auxiliary cab heater (water).

### Optional

<b>07310</b> Steering wheel, black	<b>04070</b> Two drawers
<b>02355</b> Steering wheel, leather	<b>03954</b> Refrigerator
<b>02146</b> Dashboard finish: Plateau	<b>04050</b> Refrigerator and drawer
<b>02353</b> Cab interior decoration: Argenta	<b>04069</b> Two refrigerators
<b>02350</b> Cab interior decoration: Natura	<b>02854</b> Xtra Comfort mattress for lower bunk
<b>07733</b> Driver seat: Luxury Air	<b>01775</b> Xtra Comfort mattress with topper for lower bunk
<b>07736</b> Driver seat: Super Air	<b>01177</b> Luggage carrier
<b>07737</b> Driver seat: Xtra Leather Air	<b>01066</b> Upper bunk
<b>03948</b> Single drawer	<b>06970</b> Automatic Cab Climate Control

## COMMUNICATION AND DRIVING MANAGEMENT

PACCAR Connect; Tachograph digital, Stoneridge 1C version G2V2; Speed limiter setting 85/90 km/h; DAF Infotainment Luxury with Luxury speakers; Adaptive Cruise Control with FCW and AEBS-3; Driver Performance Assistant.

### Optional

<b>09681</b> Preparation for Maut	<b>01915</b> DAF Infotainment System: Luxury Plus
<b>06211</b> DAF Infotainment System with FM/DAB/DAB+ radio	<b>16155</b> Audio equipment, makes and types
<b>03470</b> DAF Infotainment System: Exclusive, prepared	

## SAFETY AND SECURITY

DAF drowsiness detection; Lane Departure Warning System; Vehicle Stability Control (VSC); Basic engine immobiliser system.

### Optional

<b>08631</b> Air bag (driver) and 2 seat belt tensioners	<b>02569</b> No Driver State Monitoring
<b>02178</b> Main switch with second control in the cab	<b>01952</b> No DAF Side/Turn Assist

## SUSPENSION AND AXLES

Front: 8.00 t, parabolic, 163N; Rear axle load 13.00 t; Rear: air suspension, SR1344; No lifting device.

### Optional

<b>01769</b> Front axle load 7.50 t	<b>04647</b> Front springs air
<b>06257</b> Front axle load 9.00 t	<b>08191</b> Axle load monitoring

## WHEELS AND TYRES

Driven rear axle(s): 315/80R22.5; F1,315/80R22.5GO FMXSE 156/150 L Steering BBA 3P; R1,315/80R22.5GO FMXDE 156/150 L Traction BBA 3P.

### Optional

**16152** Tyre makes and types

## DRIVELINE

Electric motor type EX-D2; 310 kW; 150 kW DC charging; Battery Electric Vehicle; Rear axle ratio 2.38; ASR.

### Optional

<b>01686</b> 270 kW	<b>01756</b> 325 kW DC charging
<b>01692</b> 350 kW	<b>02843</b> Mechanical differential lock
<b>01749</b> Charging: 150 kW DC + 22 kW AC	

## BRAKE SYSTEM

Ventilated disc brakes front and rear. Dual circuit air system with electronic control (EBS). Electric driven, water cooled air compressor with automatic air heated dryer..

### Optional

**04901** Spring brake cylinders on the first front axle

## CHASSIS

Wheelbase 3.90 m / rear overhang 0.99 m; Side member height 260 mm; Standard component location; 4 HV battery packs; HV battery packs left, positions 1 and 2; HV battery pack right, position 1; Front underrun protection (FUP); Catwalk with step; Rear mudguards; Spray suppression; Work lamp LED.

### Optional

- |   |  |
|---|--|
| <b>01697</b> 3 HV battery packs               | <b>01785</b> HV battery pack right, position 2         |
| <b>01701</b> 5 HV battery packs               | <b>01791</b> HV battery packs right, positions 1 and 2 |
| <b>01634</b> HV battery pack left, position 1 | <b>16157</b> Fuel tanks, material and sizes            |
| <b>01635</b> HV battery pack left, position 2 |  |

## DRAWBAR AND TRAILER EQUIPMENT

JOST JSK37C cast iron 150+40mm; No lead-up ramps; Pneumatic trailer connection palm type; Electric connection 24 V / 2x7 pins.

### Optional

- |                                 |  |
|---------------------------------|--|
| <b>03178</b> Towing hook D= 4.3 | <b>16151</b> 5th wheel makes and heights |
|---------------------------------|--|

## BODIES AND PREPARATIONS FOR BODYING

### Optional

- |  |  |
|--|--|
| <b>02811</b> Tail lift connection Anderson | <b>02812</b> Tail lift connection REMA |
|--|--|

## POWER TAKE-OFF (PTO)

### Optional

- |   |   |
|---|---|
| <b>01809</b> E-PTO socket 650V DC < 25 kW | <b>01815</b> E-PTO socket 650V DC < 60 kW |
|---|---|

## 24V POWER SUPPLY

Batteries 2x 175 Ah..

### Optional

- |   |                                |
|---|--------------------------------|
| <b>07671</b> Batteries 2x210Ah AGM C-type | <b>06440</b> Batteries 2x230Ah |
|---|--------------------------------|

## GVM AND GCM

Chassis weight related technical GVM max 20500 kg; Driveline related max GCM 42000 kg.

## APPLICATION CONDITIONS

### Optional

- |                                   |                                       |
|-----------------------------------|---------------------------------------|
| <b>02260</b> Extra cab insulation | <b>06614</b> Anti-dust blow-up shield |
|-----------------------------------|---------------------------------------|

## SERVICE AND MAINTENANCE

Standard Warranty takes care of 1 year complete vehicle as supplied by the OEM (excl. real wear parts), 2nd year driveline and 1st year breakdown.; ITS service.

## VEHICLE DELIVERY

Minimum toolkit.

### Optional

- |                           |
|---------------------------|
| <b>07569</b> Lifting jack |
|---------------------------|

## OPTION PACKAGES

### Optional

- |                                   |                              |
|-----------------------------------|------------------------------|
| <b>17448</b> Safety pack          | <b>17623</b> No Climate Pack |
| <b>17595</b> Executive Pack XD/XF |                              |

Go to [DAF.com](https://www.daf.com) to configure your own perfect DAF.

# XF 310

FT 4X2 Tractor, Electric

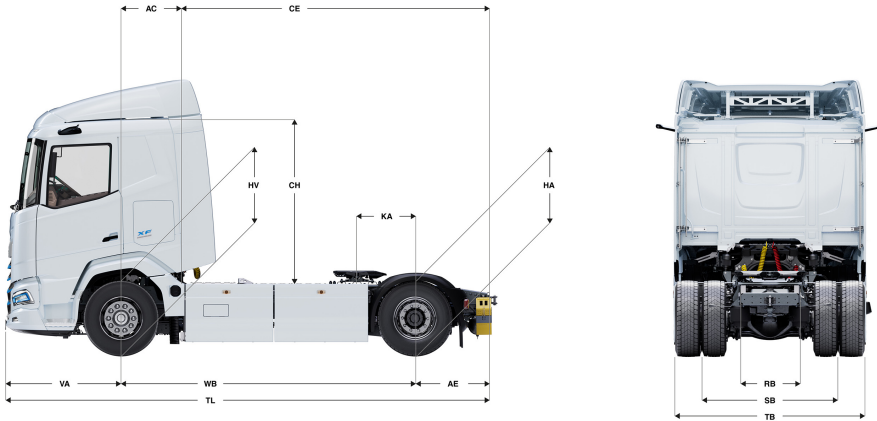

	Wheelbase - AE		Unladen weight <sup>1)</sup>			Gross Carrying Capacity			Variable dimensions								
	WB	AE <sup>5)</sup>	Front	Rear	Total	Front	Rear	Total	AC	CE	CH	KA <sup>9)</sup>	TL	HA <sup>7)</sup>	HA <sup>8)</sup>	TK <sup>9)</sup>	TW <sup>10)</sup>
<b>SLEEPER CAB</b>	3,90	0,99	6560	3404	9964	1440	8096	8036	0,83	4,06	2,23	0,77	6,42	1,00	0,98	13,76	15,15
<b>SLEEPER HIGH CAB</b>	3,90	0,99	6590	3405	9994	1410	8095	8006	0,83	4,06	2,71	0,77	6,42	1,00	0,98	13,76	15,15

OTHER DIMENSIONS VA: 1,53 HV<sup>11)</sup>: 0,98 HV<sup>12)</sup>: 0,90 RB: 0,79 SB: 1,82 TB<sup>13)</sup>: 2,48

1) GVM in conformity with registration documents.  
 2) GCM in conformity with registration documents.  
 3) Axle load with standard tyre size.  
 4) Chassis and cab weight calculated with: Standard specification items only with 3 litres of fuel, 0 litres of AdBlue® and driver of 90 kg, tolerance ± 3%. Changing of the specification can have major impact on vehicle weight.  
 5) Other AE dimensions may be available for shown WB.  
 6) Calculate customer specific KA with TOPEC.

7) Unladen height at centre of driven axle(s).  
 8) Laden height at centre of driven axle(s).  
 9) TK = turning circle between kerbs.  
 10) TW = turning circle between walls.  
 11) Unladen height at centre of front axle(s).  
 12) Laden height at centre of front axle(s).  
 13) TB is overall width at rear. (At centre of front axle 255).

Depending on the vehicle configuration a specific option may not be possible. The availability and specification of this vehicle may differ per country. For further information please contact the DAF organisation. Pictures and technical illustrations are not binding in detail and can differ from the standard specification. Subject to modification without prior notice.