

Specification sheet

XD 230

FA 4X2 Rigid, 19t



ENGINES

XD NewGen 230 PX-7 (167 kW / 227 hp)
XD NewGen 260 PX-7 (189 kW / 257 hp)
XD NewGen 290 PX-7 (212 kW / 287 hp)
XD NewGen 310 PX-7 (227 kW / 308 hp)

GVM¹⁾

18000 kg
Max. front 8000 kg
Max. rear 11500 kg

GCM²⁾

19000 kg

CAB EXTERIOR

Luxurious Day Cab with unrivalled aerodynamics for fuel efficient driving and low CO2 emissions. The huge and deep frontscreen, curved at the sides combined with large side windows offer an unsurpassed direct view for the driver, to enhance road safety. Cab length: 2030 mm; cab width: 2500 mm. Number of cab entrance steps: 2.; Cab suspension mechanical; LED head lights; DAF Corner View.

Optional

07018 Sleeper Cab	01925 Two LED work lamps for cab rear wall
06244 Sleeper High Cab	01891 Hazard beacons on cab front, prepared
01226 Cab suspension air	06629 Two hazard beacon lights
03358 External sun visor	03232 Front windscreen with solar control foil
03922 Fog lights front	03317 Rear window: double glass
00936 Auxiliary LED lights on cab roof, prepared	07343 Kerb view window co-driver door
01836 LED Skylights	01362 DAF Digital Vision System
00949 LED Skylights; aux. LED lights on cab rf, prepared	

AERODYNAMICS

Optional

00008 Adj. roof air deflector short Sleeper High Cab	00082 Adj. roof air deflector for Day Cab
00124 Adj. rf air defl.long mid >4m(!) Sleeper High Cab	00097 Adj. roof air deflector for Sleeper Cab
01538 Adj. roof air defl. long high >4m(!) Sleeper High	00020 Adj. roof air deflector long low Sleeper High Cab
02662 Adj. roof air defl. long mid XD Sleeper High Cab	

COLOURS

Cab colour E1980 Crystal White; Chassis colour grey.; Colour of bumper: Crystal White.

CAB INTERIOR

Cab interior trim colour: Luxury; Dashboard finish: Vision; Cab interior decoration: Hexagon; Driver seat: Comfort Air; Co-driver seat: cinema with fabric cover; No dashboard table; Storage compartment in centre; Automatic Temperature Control and airco; No auxiliary cab heater.

Optional

02354 Steering wheel with silver accents	02117 Third seat
02355 Steering wheel, leather	02837 Dashboard table
02353 Cab interior decoration: Argenta	03948 Single drawer
02350 Cab interior decoration: Natura	03954 Refrigerator
07733 Driver seat: Luxury Air	02838 Foam mattress for lower bunk
07736 Driver seat: Super Air	02854 Xtra Comfort mattress for lower bunk
07737 Driver seat: Xtra Leather Air	01775 Xtra Comfort mattress with topper for lower bunk
01740 Arm rest at both sides of the driver seat	06970 Automatic Cab Climate Control

COMMUNICATION AND DRIVING MANAGEMENT

PACCAR Connect; Tachograph digital, Stoneridge 1C version G2V2; Speed limiter setting 85 km/h nominal; DAF Infotainment Luxury with Luxury speakers; Adaptive Cruise Control with FCW and AEBS-3; Driver Performance Assistant.

Optional

09681 Preparation for Maut	00272 DAF infot. Exclusive prepared; Exclusive speakers
01171 DAF Infotainment System: DAB radio with speakers	01923 DAF Infotainment Luxury Plus; Exclusive speakers
01156 DAF Infotainment System: DAB radio+Luxury speakers	06211 DAF Infotainment System with FM/DAB/DAB+ radio
00146 DAF Infot. Exclusive prepared; Luxury speakers	03470 DAF Infotainment System: Exclusive, prepared
01916 DAF Infotainment Luxury Plus with Luxury speakers	01915 DAF Infotainment System: Luxury Plus
01158 DAF Infotainment Luxury with Exclusive speakers	

SAFETY AND SECURITY

Speed limit recognition; DAF drowsiness detection; Lane Departure Warning System; Vehicle Stability Control (VSC); Basic engine immobiliser system; No EC-ADR packages; Drive-off Assist; DAF Side & Turn Assist.

Optional

08631 Air bag (driver) and 2 seat belt tensioners	01929 No Drive-off Assist
02567 No Traffic Sign Assist	01952 No DAF Side/Turn Assist
02569 No Driver State Monitoring	

SUSPENSION AND AXLES

Front: 8.00 t, parabolic, 163N; Rear axle load 13.00 t; Rear: air suspension, SR1344; No lifting device.

Optional

04647 Front springs air

WHEELS AND TYRES

Driven rear axle(s): 315/70R22.5; Tyre pressure monitoring; F1,315/70R22.5GO FMXSE 156/150 L Steering BBA 3P; R1,315/70R22.5GO FMXDE 154/150 L Traction BBA 3P.

Optional

16152 Tyre makes and types

DRIVELINE

Engine PX-7, 6 cylinder diesel engine, 6.7 litres. Output 167 kW (227 hp) at 1900 rpm. Max. torque 890 Nm at 1000-1700 rpm.; Exhaust emission Euro 6; 8-speed PowerLine 8AP1000 overdrive, 4.89-0.64; Gearbox ratio 4.89-0.64; Rear axle ratio 5.57.

BRAKE SYSTEM

Exhaust brake; Ventilated disc brakes front and rear. Dual circuit air system with electronic control (EBS).Engine driven, water cooled air compressor with automatic air heated dryer.

Optional

02861 PX Engine Brake	01497 Park brake control pneumatic with spoken warning
------------------------------	---

CHASSIS

Wheelbase 4.00 m / rear overhang 1.70 m; Side member height 260 mm; Standard component location; 340 l alu fuel tank LH, height 620 mm; Tank for AdBlue® 30 l, right-hand side chassis; Spray suppression.

Optional

- 02601** Side member height 310 mm
07071 Spare wheel carrier right-hand side
16157 Fuel tanks, material and sizes
03323 Rear light with LEDs

DRAWBAR AND TRAILER EQUIPMENT

Closing member D-value = 0kN.

Optional

- 08026** Trailer coupling Rockinger D=13.0
04659 Trailer cable EBS

BODIES AND PREPARATIONS FOR BODYING

Application connector chassis.

Optional

- 09421** Additional spare wiring
08121 Tail lift application

POWER TAKE-OFF (PTO)

Optional

- 16148** PTO types and positions

24V POWER SUPPLY

Alternator 80 A, batteries 2x 140 Ah..

Optional

- 01897** Alternator 100 A
08797 Batteries 2x175Ah

GVM AND GCM

Chassis weight related technical GVM max 19000 kg; Driveline related max GCM 19000 kg.

APPLICATION CONDITIONS

Air intake front.

Optional

- 02260** Extra cab insulation
03648 Cyclonic air intake high

SERVICE AND MAINTENANCE

Standard Warranty takes care of 1 year complete vehicle as supplied by the OEM (excl. real wear parts), 2nd year driveline and 1st year breakdown.; ITS service.

VEHICLE DELIVERY

Minimum toolkit.

Optional

- 07569** Lifting jack

OPTION PACKAGES

Optional

- 17595** Executive Pack XD/XF



Go to [DAF.com](https://www.daf.com) to configure your own perfect DAF.

XD 230

FA 4X2 Rigid, 19t

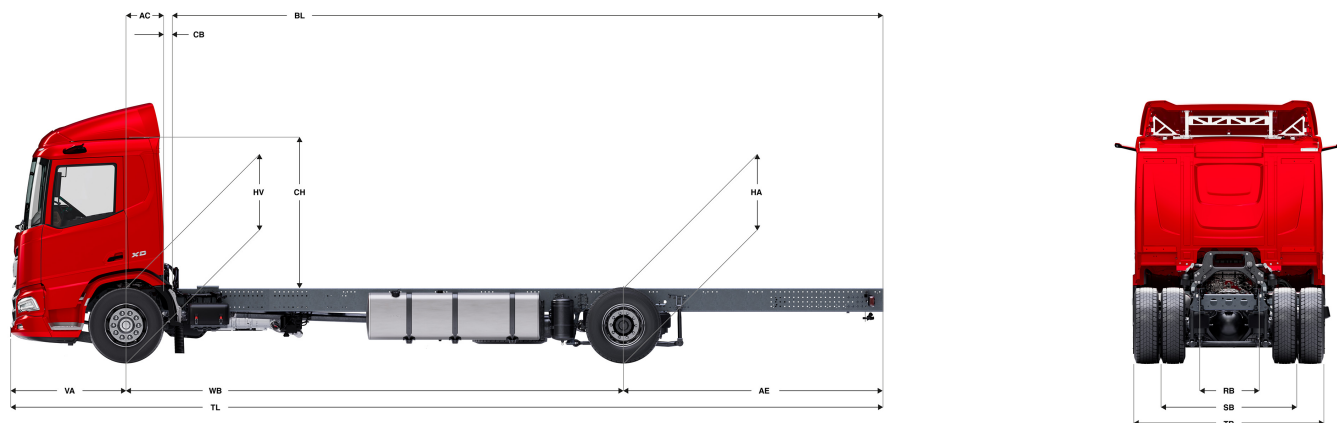

		Wheelbase - AE		Unladen weight ¹⁾			Gross Carrying Capacity			Variable dimensions									
		WB	AE ⁵⁾	Front	Rear	Total	Front	Rear	Total	AC	CB ⁶⁾	CH ⁷⁾	BL ⁸⁾	BL	TL	HA ⁹⁾	HA ¹⁰⁾	TK ¹¹⁾	TW ¹²⁾
DAY CAB	4,00	1,70	3816	1925	5741	4184	9575	12259	0,50	0,07	2,06	4,34	5,54	7,23	0,97	0,94	14,02	15,41	
	4,20	1,80	3811	1945	5756	4189	9555	12244	0,50	0,07	2,06	4,61	5,87	7,53	0,97	0,94	14,53	15,94	
	4,50	1,95	3806	1990	5796	4194	9510	12204	0,50	0,07	2,06	5,00	6,36	7,98	0,97	0,94	15,31	16,73	
	4,70	2,05	3803	2008	5810	4197	9492	12190	0,50	0,07	2,06	5,27	6,69	8,28	0,97	0,94	15,83	17,26	
	4,90	2,35	3794	2040	5834	4206	9460	12166	0,50	0,07	2,06	5,54	7,01	8,78	0,97	0,94	16,35	17,79	
	5,10	2,75	3846	2183	6029	4154	9317	11971	0,50	0,07	2,06	5,80	7,36	9,38	0,97	0,94	16,87	18,32	
	5,40	2,65	3864	2196	6060	4136	9304	11940	0,50	0,07	2,06	6,21	7,88	9,58	0,97	0,94	17,66	19,11	
	5,70	2,65	3872	2212	6084	4128	9288	11916	0,50	0,07	2,06	6,62	8,38	9,88	0,97	0,94	18,44	19,90	
	6,10	1,15	4013	2173	6186	3987	9327	11814	0,50	0,07	2,06	7,28	9,16	8,78	0,97	0,95	19,49	20,96	
6,60	1,15	3959	2141	6100	4041	9359	11900	0,50	0,07	2,01	7,93	9,96	9,28	1,02	1,00	20,80	22,28		
6,90	1,15	3964	2155	6119	4036	9345	11881	0,50	0,07	2,01	8,34	10,47	9,58	1,02	1,00	21,59	23,08		
SLEEPER CAB	4,00	1,70	3919	1932	5851	4081	9568	12149	0,83	0,07	2,06	3,72	4,93	7,23	0,97	0,94	14,02	15,41	
	4,20	1,80	3914	1951	5866	4086	9549	12134	0,83	0,07	2,06	3,99	5,26	7,53	0,97	0,94	14,53	15,94	
	4,50	1,95	3910	1996	5906	4090	9504	12094	0,83	0,07	2,06	4,39	5,76	7,98	0,97	0,94	15,31	16,73	
	4,70	2,05	3907	2013	5920	4093	9487	12080	0,83	0,07	2,06	4,66	6,09	8,28	0,97	0,94	15,83	17,26	
	4,90	2,35	3898	2045	5944	4102	9455	12056	0,83	0,07	2,06	4,93	6,42	8,78	0,97	0,94	16,35	17,79	
	5,10	2,75	3950	2189	6139	4050	9311	11861	0,83	0,07	2,06	5,19	6,76	9,38	0,97	0,94	16,87	18,32	
	5,40	2,65	3969	2201	6170	4031	9299	11830	0,83	0,07	2,06	5,61	7,29	9,58	0,97	0,94	17,66	19,11	
	5,70	2,65	3977	2217	6194	4023	9283	11806	0,83	0,07	2,06	6,03	7,79	9,88	0,97	0,94	18,44	19,90	
	6,10	1,15	4119	2177	6296	3881	9323	11704	0,83	0,07	2,06	6,67	8,58	8,78	0,97	0,95	19,49	20,96	
6,60	1,15	4065	2145	6210	3935	9355	11790	0,83	0,07	2,01	7,35	9,39	9,28	1,02	1,00	20,80	22,28		
6,90	1,15	4070	2159	6229	3930	9341	11771	0,83	0,07	2,01	7,76	9,91	9,58	1,02	1,00	21,59	23,08		
SLEEPER HIGH CAB	4,00	1,70	3948	1933	5881	4052	9567	12119	0,83	0,07	2,54	3,74	4,94	7,23	0,97	0,94	14,02	15,41	
	4,20	1,80	3943	1952	5895	4057	9548	12105	0,83	0,07	2,54	4,00	5,28	7,53	0,97	0,94	14,53	15,94	
	4,50	1,95	3939	1997	5936	4061	9503	12064	0,83	0,07	2,54	4,41	5,78	7,98	0,97	0,94	15,31	16,73	
	4,70	2,05	3936	2014	5950	4064	9486	12050	0,83	0,07	2,54	4,67	6,10	8,28	0,97	0,94	15,83	17,26	
	4,90	2,35	3927	2046	5973	4073	9454	12027	0,83	0,07	2,54	4,95	6,43	8,78	0,97	0,94	16,35	17,79	
	5,10	2,75	3980	2189	6169	4020	9311	11831	0,83	0,07	2,54	5,22	6,79	9,38	0,97	0,94	16,87	18,32	
	5,40	2,65	3998	2201	6200	4002	9299	11800	0,83	0,07	2,54	5,63	7,30	9,58	0,97	0,94	17,66	19,11	
	5,70	2,65	4006	2217	6223	3994	9283	11777	0,83	0,07	2,54	6,04	7,82	9,88	0,97	0,94	18,44	19,90	
	6,10	1,15	4148	2177	6325	3852	9323	11675	0,83	0,07	2,54	6,70	8,61	8,78	0,97	0,95	19,49	20,96	
6,60	1,15	4094	2146	6239	3906	9354	11761	0,83	0,07	2,49	7,36	9,42	9,28	1,02	1,00	20,80	22,28		
6,90	1,15	4099	2159	6258	3901	9341	11742	0,83	0,07	2,49	7,79	9,93	9,58	1,02	1,00	21,59	23,08		

OTHER DIMENSIONS VA: 1,53 HV¹³⁾: 1,00 HV¹⁴⁾: 0,93 RB: 0,79 SB: 1,82 TB¹⁵⁾: 2,48

- GVM in conformity with registration documents.
- GCM in conformity with registration documents.
- Axle load with standard tyre size.
- Chassis and cab weight calculated with: Standard specification items only with 340 litres of fuel, 30 litres of AdBlue® and driver of 90 kg, tolerance ± 3%. Changing of the specification can have major impact on vehicle weight.
- Other AE dimensions may be available for shown WB. Modify rear overhang to the calculated body length.
- CB is based on standard air intake and/or exhaust.
- Cab height is measured from frame member to closed cabin roof hatch.

- Calculate customer specific body length with TOPEC. Body lengths shown based on evenly distributed load at max axle load.
- Unladen height at centre of driven axle(s).
- Laden height at centre of driven axle(s).
- TK = turning circle between kerbs.
- TW = turning circle between walls.
- Unladen height at centre of front axle(s).
- Laden height at centre of front axle(s).
- TB is overall width at rear. (At centre of front axle 255).

Depending on the vehicle configuration a specific option may not be possible. The availability and specification of this vehicle may differ per country. For further information please contact the DAF organisation. Pictures and technical illustrations are not binding in detail and can differ from the standard specification. Subject to modification without prior notice.