

Specification sheet

XD 370

FAD 8X4 Rigid



ENGINES

- XD NewGen 370 MX-11 (270 kW / 367 hp)
- XD NewGen 410 MX-11 (300 kW / 408 hp)
- XD NewGen 450 MX-11 (330 kW / 449 hp)

GVM¹⁾

32000 kg

Max. front 16000 kg

Max. rear 19000 kg

GCM²⁾

35500 kg

CAB EXTERIOR

Luxurious Day Cab with unrivalled aerodynamics for fuel efficient driving and low CO2 emissions. The huge and deep frontscreen, curved at the sides combined with large side windows offer an unsurpassed direct view for the driver, to enhance road safety. Cab length: 2030 mm; cab width: 2500 mm. Number of cab entrance steps: 3.; Cab suspension mechanical; LED head lights; DAF Corner View.

Optional

07018 Sleeper Cab	00949 LED Skylights; aux. LED lights on cab rf, prepared
06244 Sleeper High Cab	01925 Two LED work lamps for cab rear wall
03353 Chassis front execution: protruding	01891 Hazard beacons on cab front, prepared
07586 Chassis front execution: robust	06629 Two hazard beacon lights
01226 Cab suspension air	03232 Front windscreen with solar control foil
03358 External sun visor	03317 Rear window: double glass
03922 Fog lights front	07343 Kerb view window co-driver door
00936 Auxiliary LED lights on cab roof, prepared	01362 DAF Digital Vision System
01836 LED Skylights	

AERODYNAMICS

Optional

00008 Adj. roof air deflector short Sleeper High Cab	00082 Adj. roof air deflector for Day Cab
00124 Adj. rf air defl.long mid >4m(!) Sleeper High Cab	00097 Adj. roof air deflector for Sleeper Cab
01538 Adj. roof air defl. long high >4m(!) Sleeper High	00020 Adj. roof air deflector long low Sleeper High Cab

COLOURS

Cab colour E1980 Crystal White; Chassis colour grey.; Colour of bumper: Crystal White.

CAB INTERIOR

Cab interior trim colour: Luxury; Dashboard finish: Vision; Cab interior decoration: Hexagon; Driver seat: Comfort Air; Co-driver seat: cinema with fabric cover; No dashboard table; Storage compartment in centre; Automatic Temperature Control and airco; No auxiliary cab heater.

Optional

02354 Steering wheel with silver accents	02117 Third seat
02355 Steering wheel, leather	02837 Dashboard table
02353 Cab interior decoration: Argenta	03948 Single drawer
02350 Cab interior decoration: Natura	03954 Refrigerator
07733 Driver seat: Luxury Air	02838 Foam mattress for lower bunk
07736 Driver seat: Super Air	02854 Xtra Comfort mattress for lower bunk
07737 Driver seat: Xtra Leather Air	01775 Xtra Comfort mattress with topper for lower bunk
09541 Arm rest driver seat	06970 Automatic Cab Climate Control
01740 Arm rest at both sides of the driver seat	

COMMUNICATION AND DRIVING MANAGEMENT

PACCAR Connect; Tachograph digital, Stoneridge 1C version G2V2; Speed limiter setting 85/90 km/h; DAF Infotainment Luxury with Luxury speakers; Adaptive Cruise Control (ACC) with FCW; Driver Performance Assistant.

Optional

09681 Preparation for Maut	09908 Cruise control
06211 DAF Infotainment System with FM/DAB/DAB+ radio	08023 Adaptive Cruise Control with FCW and AEBS-3
03470 DAF Infotainment System: Exclusive, prepared	06991 Predictive Cruise Control
01915 DAF Infotainment System: Luxury Plus	

SAFETY AND SECURITY

Lane Departure Warning System; No vehicle stability control; Basic engine immobiliser system; No EC-ADR packages; DAF Side & Turn Assist.

Optional

08631 Air bag (driver) and 2 seat belt tensioners	00795 Safety regulations EC ADR
--	--

SUSPENSION AND AXLES

Front: 2x 8.00 t, parabolic, 163N; Rear axle load 9.50+ 9.50 t; Rear: 19.00 t, trapezium, SR1132T; No lifting device.

Optional

03299 Front axles load 7.10 + 7.10 t	01372 Rear springs air
03280 Front axles load 7.50 + 7.50 t	04549 Rear axle load 10.50+ 10.50 t
06264 Front axles load 9.00 + 9.00 t	04563 Rear axle load 13.00+ 13.00 t
07494 Rear axle HR1670T	08191 Axle load monitoring
02788 Rear axle SR1360T	

WHEELS AND TYRES

Driven rear axle(s): 315/70R22.5; F1,315/70R22.5GO FMXSE 156/150 L Steering BBA 3P; R1,315/70R22.5GO FMXDE 154/150 L Traction BBA 3P.

Optional

16152 Tyre makes and types

DRIVELINE

Engine MX-11, multi torque 6 cylinder diesel engine, 10.8 litres. Output 270 kW (367 hp) at 1600 rpm. Maximum torque 1950 Nm at 900-1125 rpm.; Exhaust emission Euro 6; Eco fuel; 12-speed TraXon 12TX2610 OD, 12.92-0.77; Gearbox ratio 12.92-0.77; Rear axle ratio 3.73.

Optional

07110 Eco performance	09638 Off-road applications
02313 Gearbox direct drive	01498 Off-road applications with Rock-free function
01514 Urge-to-move	03720 No ASR
09637 Liquid transport	

BRAKE SYSTEM

MX Engine Brake; Ventilated disc brakes at front, rear tandem axle with drum brakes. Dual circuit air system with electronic control (EBS)..

Optional

09920 No MX Engine Brake	01497 Park brake control pneumatic with spoken warning
02715 ZF Intarder	
01572 Park brake control electro-pneumatic	06127 Driven rear axle with disc brakes

CHASSIS

Wheelbase 5.70 m / rear overhang 1.65 m; Side member height 310 mm; Standard component location; 340 l alu fuel tank LH, height 620 mm; Tank for AdBlue® 45 l, left below battery box; Front underrun protection (FUP); Spray suppression.

Optional

- 16157** Fuel tanks, material and sizes
07070 Spare wheel carrier left-hand side
- 03323** Rear light with LEDs

DRAWBAR AND TRAILER EQUIPMENT

Closing member D-value = 0kN.

Optional

- 07033** Trailer coupling Ringfeder D=13.7
07034 Trailer coupling Ringfeder D=20.0
08026 Trailer coupling Rockinger D=13.0
- 08027** Trailer coupling Rockinger D=20.0
04659 Trailer cable EBS

BODIES AND PREPARATIONS FOR BODYING

Application connector chassis.

Optional

- 09421** Additional spare wiring

POWER TAKE-OFF (PTO)

Optional

- 16148** PTO types and positions

24V POWER SUPPLY

Alternator 110 A, batteries 2x 140 Ah..

Optional

- 04492** Alternator 130 A
08775 Alternator 150 A
08797 Batteries 2x175Ah
- 07671** Batteries 2x210Ah AGM C-type
06440 Batteries 2x230Ah

GVM AND GCM

Chassis weight related technical GVM max 32000 kg; Driveline related max GCM 35500 kg class 2.

Optional

- 01208** Driveline related max GCM 35500 kg class 3
00200 Driveline related max GCM 38000 kg class 2
00209 Driveline related max GCM 40000 kg class 3
03673 Driveline related max GCM 44000 kg class 2
03675 Driveline related max GCM 50000 kg class 3
- 00778** Driveline related max GCM 58000 kg class 2
07279 Driveline related max GCM 60000 kg class 2
00818 Driveline related max GCM 60000 kg class 3
00157 Driveline related max GCM 61000 kg class 2

APPLICATION CONDITIONS

Air intake front.

Optional

- 02260** Extra cab insulation
03648 Cyclonic air intake high
- 06614** Anti-dust blow-up shield

SERVICE AND MAINTENANCE

Standard Warranty takes care of 1 year complete vehicle as supplied by the OEM (excl. real wear parts), 2nd year driveline and 1st year breakdown.; ITS service.

Optional

- 08311** Service interval extended

VEHICLE DELIVERY

Minimum toolkit.

Optional

- 07569** Lifting jack

OPTION PACKAGES

Optional

- 17448** Safety pack
17595 Executive Pack XD/XF



Go to [DAF.com](https://www.daf.com) to configure your own perfect DAF.

XD 370

FAD 8X4 Rigid

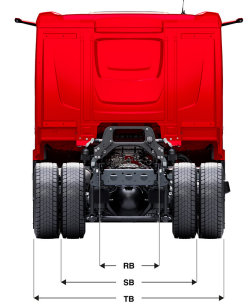
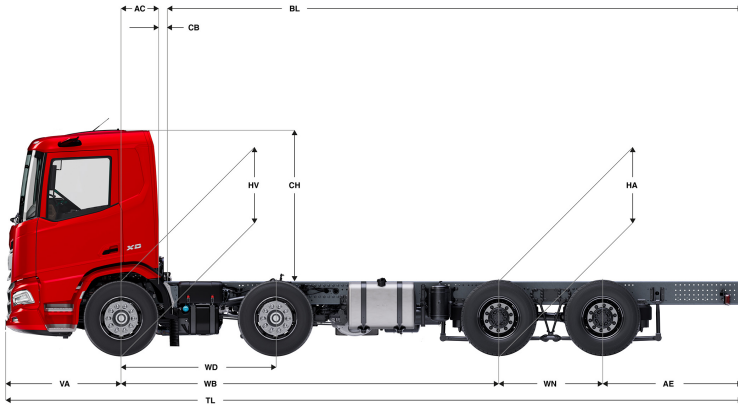

	Wheelbase - AE		Unladen weight ¹⁾			Gross Carrying Capacity			Variable dimensions									
	WB	AE ⁵⁾	Front	Rear	Total	Front	Rear	Total	AC	CB ⁶⁾	CH	BL ⁷⁾	BL	TL	HA ⁸⁾	HA ⁹⁾	TK ¹⁰⁾	TW ¹¹⁾
DAY CAB	5,05	1,65	6794	3062	9856	9206	15938	22144	0,50	0,07	2,01	6,01	6,65	8,23	1,14	1,08	18,39	19,70
	5,30	1,65	6841	3226	10066	9159	15774	21934	0,50	0,07	2,01	6,32	7,00	8,48	1,14	1,08	19,12	20,43
	5,70	1,65	6764	2962	9726	9236	16038	22274	0,50	0,07	2,01	6,39	7,64	8,88	1,16	1,09	20,28	21,60
	6,40	2,15	6652	3193	9845	9348	15807	22155	0,50	0,07	2,01	7,13	8,58	10,08	1,16	1,09	22,32	23,65
SLEEPER CAB	WB	AE ⁵⁾	Front	Rear	Total	Front	Rear	Total	AC	CB ⁶⁾	CH	BL ⁷⁾	BL	TL	HA ⁸⁾	HA ⁹⁾	TK ¹⁰⁾	TW ¹¹⁾
	5,05	1,65	6931	3039	9970	9069	15961	22030	0,83	0,07	2,01	5,39	6,03	8,23	1,14	1,08	18,39	19,70
	5,30	1,65	6977	3203	10180	9023	15797	21820	0,83	0,07	2,01	5,69	6,37	8,48	1,14	1,08	19,12	20,43
	5,70	1,65	6898	2941	9840	9102	16059	22160	0,83	0,07	2,01	5,77	7,02	8,88	1,16	1,09	20,28	21,60
6,40	2,15	6784	3175	9959	9216	15825	22041	0,83	0,07	2,01	6,51	7,96	10,08	1,16	1,09	22,32	23,65	
SLEEPER HIGH CAB	WB	AE ⁵⁾	Front	Rear	Total	Front	Rear	Total	AC	CB ⁶⁾	CH	BL ⁷⁾	BL	TL	HA ⁸⁾	HA ⁹⁾	TK ¹⁰⁾	TW ¹¹⁾
	5,05	1,65	6969	3030	9999	9031	15970	22001	0,83	0,07	2,49	5,40	6,03	8,23	1,14	1,08	18,39	19,70
	5,30	1,65	7014	3195	10209	8986	15805	21791	0,83	0,07	2,49	5,70	6,38	8,48	1,14	1,08	19,12	20,43
	5,70	1,65	6935	2934	9869	9065	16066	22131	0,83	0,07	2,49	5,77	7,04	8,88	1,16	1,09	20,28	21,60
6,40	2,15	6820	3169	9989	9180	15831	22011	0,83	0,07	2,49	6,52	7,98	10,08	1,16	1,09	22,32	23,65	

OTHER DIMENSIONS	VA: 1,53	WD: 2,05	WT: 1,40	HV ¹²⁾ : 1,06	HV ¹³⁾ : 0,97	RB: 0,79	SB: 1,82	TB ¹⁴⁾ : 2,48
------------------	----------	----------	----------	--------------------------	--------------------------	----------	----------	--------------------------

1) GVM in conformity with registration documents.
 2) GCM in conformity with registration documents.
 3) Axle load with standard tyre size.
 4) Chassis and cab weight calculated with: Standard specification items only with 340 litres of fuel, 45 litres of AdBlue® and driver of 90 kg, tolerance ± 3%. Changing of the specification can have major impact on vehicle weight.
 5) Other AE dimensions may be available for shown WB. Modify rear overhang to the calculated body length.
 6) CB is based on standard air intake and/or exhaust.
 7) Calculate customer specific body length with TOPEC. Body lengths shown based on evenly distributed load at max axle load.

8) Unladen height at centre of driven axle(s).
 9) Laden height at centre of driven axle(s).
 10) TK = turning circle between kerbs.
 11) TW = turning circle between walls.
 12) Unladen height at centre of front axle(s).
 13) Laden height at centre of front axle(s).
 14) TB is overall width at rear. (At centre of front axle 255).

Depending on the vehicle configuration a specific option may not be possible. The availability and specification of this vehicle may differ per country. For further information please contact the DAF organisation. Pictures and technical illustrations are not binding in detail and can differ from the standard specification. Subject to modification without prior notice.