

# Specification sheet

# XFC 410

FT 4X2 Tractor

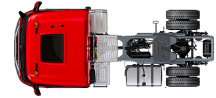

## ENGINES

XFC NewGen 370 MX-11 (270 kW / 367 hp)
XFC NewGen 410 MX-11 (300 kW / 408 hp)
XFC NewGen 450 MX-11 (330 kW / 449 hp)
XFC NewGen 430 MX-13 (315 kW / 428 hp)
XFC NewGen 480 MX-13 (355 kW / 483 hp)
XFC NewGen 530 MX-13 (390 kW / 530 hp)

## GVM<sup>1)</sup>

18000 kg
Max. front 8000 kg
Max. rear 11500 kg

## GCM<sup>2)</sup>

44000 kg

016GG0209CAAA - 202513D - 11-12-2024

DAF Trucks Ltd, UK, Haddenham, HP17 8LJ, [www.daf.co.uk](http://www.daf.co.uk)

## CAB EXTERIOR

Luxurious Sleeper Cab with unrivalled aerodynamics for fuel efficient driving and low CO2 emissions. The huge and deep frontscreen, curved at the sides combined with large side windows offer an unsurpassed direct view for the driver, to enhance road safety. The cab interior is extremely comfortable for driving, living and sleeping with unprecedented spaciousness and practical layout. Cab length: 2360 mm; cab width: 2500 mm. Number of cab steps: 3.; Cab suspension mechanical; LED head and fog lights; Front view mirror.

### Optional

<b>07017</b> Day Cab	<b>01925</b> Two LED work lamps for cab rear wall
<b>06244</b> Sleeper High Cab	<b>01891</b> Hazard beacons on cab front, prepared
<b>03358</b> External sun visor	<b>06629</b> Two hazard beacon lights
<b>04291</b> Cab step flexible	<b>03232</b> Front windscreen with solar control foil
<b>06790</b> Aluminium ladder 1-piece	<b>03317</b> Rear window: double glass
<b>06791</b> Aluminium ladder 2-piece	<b>07343</b> Kerb view window co-driver door
<b>00936</b> Auxiliary LED lights on cab roof, prepared	<b>01550</b> No front view mirror
<b>01836</b> LED Skylights	<b>01362</b> DAF Digital Vision System
<b>00949</b> LED Skylights; aux. LED lights on cab rf, prepared	<b>01913</b> DAF Corner View

## AERODYNAMICS

### Optional

<b>00010</b> Adj. roof air deflector short Sleeper High Cab	<b>03419</b> Side collars, extended. One side hinged
<b>01904</b> Adj. rf air defl. long low >4m(!) XF Sl. High Cab	<b>03076</b> Side collars, extended. Both sides hinged
<b>00138</b> Adj. rf air defl. long mid >4m(!) Sleeper High Cab	<b>04146</b> Side skirts
<b>01552</b> Adj. roof air defl. long high >4m(!) Sleeper High	<b>01122</b> Side skirts
<b>00094</b> Adj. roof air deflector for Day Cab	<b>01126</b> Side skirts with bottom extensions
<b>00118</b> Adj. roof air deflector for Sleeper Cab	<b>01127</b> Side skirts with top extensions
<b>04906</b> Side collars, one side hinged	<b>01135</b> Side skirts with extensions at top and bottom
<b>03074</b> Side collars, both sides hinged	

## COLOURS

Cab colour E1980 Crystal White; Chassis colour grey.; Colour of bumper: grey.

## CAB INTERIOR

Cab interior trim colour: Luxury; Dashboard finish: Vision; Cab interior decoration: Hexagon; Driver seat: Comfort Air; Arm rest driver seat; Co-driver seat: cinema with fabric cover; Dashboard table; Storage compartment in centre; Automatic Temperature Control and airco; Auxiliary cab heater (water).

### Optional

<b>07310</b> Steering wheel, black	<b>03954</b> Refrigerator
<b>02355</b> Steering wheel, leather	<b>04050</b> Refrigerator and drawer
<b>02146</b> Dashboard finish: Plateau	<b>04069</b> Two refrigerators
<b>02353</b> Cab interior decoration: Argenta	<b>31364</b> Without feature: Lower bunk mattress
<b>02350</b> Cab interior decoration: Natura	<b>02854</b> Xtra Comfort mattress for lower bunk
<b>07733</b> Driver seat: Luxury Air	<b>01775</b> Xtra Comfort mattress with topper for lower bunk
<b>07736</b> Driver seat: Super Air	<b>01177</b> Luggage carrier
<b>07737</b> Driver seat: Xtra Leather Air	<b>01066</b> Upper bunk
<b>02117</b> Third seat	<b>06970</b> Automatic Cab Climate Control
<b>03948</b> Single drawer	<b>01967</b> Park air conditioning, integrated
<b>04070</b> Two drawers	

## COMMUNICATION AND DRIVING MANAGEMENT

PACCAR Connect; Tachograph digital, Stoneridge 1C version G2V2; Speed limiter setting 85/90 km/h; DAF Infotainment Luxury with Luxury speakers; Adaptive Cruise Control with FCW and AEBS-3; Driver Performance Assistant.

### Optional

<b>09681</b> Preparation for Maut	<b>01915</b> DAF Infotainment System: Luxury Plus
<b>06211</b> DAF Infotainment System with FM/DAB/DAB+ radio	<b>16161</b> No audio equipment, makes and types
<b>03470</b> DAF Infotainment System: Exclusive, prepared	

## SAFETY AND SECURITY

DAF drowsiness detection; Lane Departure Warning System; Vehicle Stability Control (VSC); Basic engine immobiliser system.

### Optional

<b>08631</b> Air bag (driver) and 2 seat belt tensioners	<b>06410</b> Safe Load Pass preparation
<b>02178</b> Main switch with second control in the cab	<b>00795</b> Safety regulations EC ADR
<b>02569</b> No Driver State Monitoring	<b>01952</b> No DAF Side/Turn Assist

## SUSPENSION AND AXLES

Front: 8.00 t, parabolic, 167N; Rear axle load 13.00 t; Rear: air suspension, SR1344; No lifting device.

### Optional

<b>06257</b> Front axle load 9.00 t	<b>04588</b> Rear axle SR1347
<b>04057</b> Rear axle HR1356	<b>08191</b> Axle load monitoring

## WHEELS AND TYRES

Driven rear axle(s): 315/80R22.5; F1,315/80R22.5GO FMXSE 156/150 L Steering BBA 3P; R1,315/80R22.5GO FMXDE 156/150 L Traction BBA 3P.

### Optional

<b>16152</b> Tyre makes and types
-----------------------------------

## DRIVELINE

Engine MX-11, multi torque 6 cylinder diesel engine, 10.8 litres. Output 300 kW (408 hp) at 1600 rpm. Maximum torque 2150 Nm at 900-1125 rpm.; Exhaust emission Euro 6; Eco fuel; 12-speed TraXon 12TX2010 DD, 16.69-1.00; Gearbox ratio 16.69-1.00; Rear axle ratio 2.47; ASR.

## Optional

<b>07110</b> Eco performance	<b>08371</b> Long Combination Vehicle (LCV)
<b>02314</b> Gearbox overdrive	
<b>09636</b> Heavy haulage	<b>09638</b> Off-road applications
<b>09637</b> Liquid transport	<b>01498</b> Off-road applications with Rock-free function

## BRAKE SYSTEM

MX Engine Brake; Ventilated disc brakes front and rear. Dual circuit air system with electronic control (EBS). Engine driven, water cooled air compressor with automatic air heated dryer..

### Optional

<b>02715</b> ZF Intarder	<b>01497</b> Park brake control pneumatic with spoken warning
<b>01572</b> Park brake control electro-pneumatic	
	<b>04901</b> Spring brake cylinders on the first front axle

## CHASSIS

Wheelbase 3.80 m / rear overhang 0.99 m; Side member height 260 mm; Standard component location; 430 l alu fuel tank LH, height 620 mm; Tank for AdBlue® 80 l, on left-hand mudguard; No front underrun protection; Catwalk with step; Rear mudguards; Spray suppression; Work lamp LED.

### Optional

<b>08740</b> Free space between front and rear axle	<b>16157</b> Fuel tanks, material and sizes
<b>07007</b> Component-free right hand side, 1500 mm	<b>07071</b> Spare wheel carrier right-hand side
<b>03598</b> Component-free right hand side, 1700 mm	<b>03323</b> Rear light with LEDs
<b>02883</b> Component-free right-hand side, 1900 mm	

## DRAWBAR AND TRAILER EQUIPMENT

JOST JSK37C cast iron 150+40mm; No lead-up ramps; Pneumatic trailer connection C-type; Electric connection 24 V / 2x7 pins.

### Optional

<b>03178</b> Towing hook D= 4.3	<b>16151</b> 5th wheel makes and heights
---------------------------------	--

## BODIES AND PREPARATIONS FOR BODYING

### Optional

<b>02811</b> Tail lift connection Anderson	<b>02812</b> Tail lift connection REMA
--	--

## POWER TAKE-OFF (PTO)

### Optional

<b>16148</b> PTO types and positions
--------------------------------------

## 24V POWER SUPPLY

Alternator 110 A, batteries 2x 175 Ah..

### Optional

<b>04492</b> Alternator 130 A	<b>07671</b> Batteries 2x210Ah AGM C-type
<b>08775</b> Alternator 150 A	
<b>01257</b> Batteries 2x140Ah	<b>06440</b> Batteries 2x230Ah

## GVM AND GCM

Chassis weight related technical GVM max 20500 kg; Driveline related max GCM 44000 kg class 2.

## APPLICATION CONDITIONS

Air intake front.

### Optional

<b>02260</b> Extra cab insulation	<b>06614</b> Anti-dust blow-up shield
<b>03648</b> Cyclonic air intake high	<b>06620</b> Anti-dust blow-up shield + bugscreen

## SERVICE AND MAINTENANCE

Standard Warranty takes care of 1 year complete vehicle as supplied by the OEM (excl. real wear parts), 2nd year driveline and 1st year breakdown.; ITS service.

### Optional

<b>08311</b> Service interval extended
--

## VEHICLE DELIVERY

Minimum toolkit.

### Optional

<b>07569</b> Lifting jack
---------------------------

## OPTION PACKAGES

### Optional

<b>17448</b> Safety pack	<b>17625</b> Climate Pack
<b>17595</b> Executive Pack XD/XF	

Go to [DAF.com](https://www.daf.com) to configure your own perfect DAF.

# XFC 410

## FT 4X2 Tractor

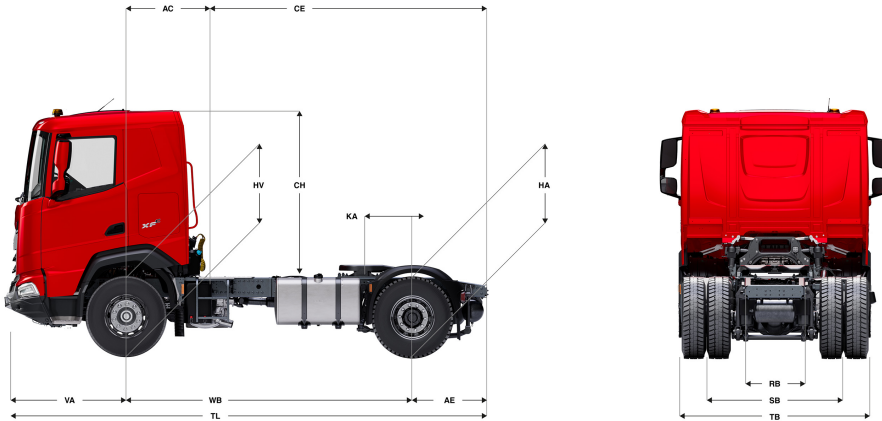

	Wheelbase - AE		Unladen weight <sup>1)</sup>			Gross Carrying Capacity			Variable dimensions								
	WB	AE <sup>5)</sup>	Front	Rear	Total	Front	Rear	Total	AC	CE	CH	KA <sup>6)</sup>	TL	HA <sup>7)</sup>	HA <sup>8)</sup>	TK <sup>9)</sup>	TW <sup>10)</sup>
DAY CAB	3,60	0,99	4990	2137	7127	3010	9363	10873	0,50	4,09	2,23	0,47	6,20	1,08	1,06	12,99	14,39
	3,80	0,99	4986	2152	7139	3014	9348	10861	0,50	4,29	2,23	0,67	6,40	1,08	1,06	13,50	14,92
	4,00	0,99	5045	2223	7268	2955	9277	10732	0,50	4,49	2,23	0,72	6,60	1,08	1,06	14,02	15,44
SLEEPER CAB	WB	AE <sup>5)</sup>	Front	Rear	Total	Front	Rear	Total	AC	CE	CH	KA <sup>6)</sup>	TL	HA <sup>7)</sup>	HA <sup>8)</sup>	TK <sup>9)</sup>	TW <sup>10)</sup>
	3,60	0,99	5111	2150	7260	2889	9350	10740	0,83	3,76	2,23	0,47	6,20	1,08	1,05	12,99	14,39
	3,80	0,99	5108	2164	7272	2892	9336	10728	0,83	3,96	2,23	0,67	6,40	1,08	1,05	13,50	14,92
SLEEPER HIGH CAB	WB	AE <sup>5)</sup>	Front	Rear	Total	Front	Rear	Total	AC	CE	CH	KA <sup>6)</sup>	TL	HA <sup>7)</sup>	HA <sup>8)</sup>	TK <sup>9)</sup>	TW <sup>10)</sup>
	3,60	0,99	5141	2150	7291	2859	9350	10709	0,83	3,76	2,71	0,47	6,20	1,08	1,05	12,99	14,39
	3,80	0,99	5138	2164	7303	2862	9336	10697	0,83	3,96	2,71	0,67	6,40	1,08	1,05	13,50	14,92
	4,00	0,99	5198	2234	7432	2802	9266	10568	0,83	4,16	2,71	0,72	6,60	1,08	1,06	14,02	15,44

OTHER DIMENSIONS VA: 1,61 HV<sup>11)</sup>: 1,14 HV<sup>12)</sup>: 1,05 RB: 0,79 SB: 1,82 TB<sup>13)</sup>: 2,48

- 1) GVM in conformity with registration documents.
- 2) GCM in conformity with registration documents.
- 3) Axle load with standard tyre size.
- 4) Chassis and cab weight calculated with: Standard specification items only with 430 litres of fuel, 80 litres of AdBlue® and driver of 90 kg, tolerance ± 3%. Changing of the specification can have major impact on vehicle weight.
- 5) Other AE dimensions may be available for shown WB.
- 6) Calculate customer specific KA with TOPEC.

- 7) Unladen height at centre of driven axle(s).
- 8) Laden height at centre of driven axle(s).
- 9) TK = turning circle between kerbs.
- 10) TW = turning circle between walls.
- 11) Unladen height at centre of front axle(s).
- 12) Laden height at centre of front axle(s).
- 13) TB is overall width at rear. (At centre of front axle 255).

Depending on the vehicle configuration a specific option may not be possible. The availability and specification of this vehicle may differ per country. For further information please contact the DAF organisation. Pictures and technical illustrations are not binding in detail and can differ from the standard specification. Subject to modification without prior notice.