

Specification sheet

XD 300

FT 4X2 Tractor



ENGINES

XD NewGen 300 MX-11 (220 kW / 299 hp)
XD NewGen 340 MX-11 (251 kW / 341 hp)
XD NewGen 370 MX-11 (270 kW / 367 hp)
XD NewGen 410 MX-11 (300 kW / 408 hp)
XD NewGen 450 MX-11 (330 kW / 449 hp)

GVM¹⁾

18000 kg
Max. front 8000 kg
Max. rear 11500 kg

GCM²⁾

40000 kg

016GG0101AAAA - 202513C - 06-12-2024

DAF Trucks Ltd, UK, Haddenham, HP17 8LJ, www.daf.co.uk

CAB EXTERIOR

Luxurious Sleeper Cab with unrivalled aerodynamics for fuel efficient driving and low CO2 emissions. The huge and deep frontscreen, curved at the sides combined with large side windows offer an unsurpassed direct view for the driver, to enhance road safety. The cab interior is extremely comfortable for driving, living and sleeping with unprecedented spaciousness and practical layout. Cab length: 2360 mm; cab width: 2500 mm. Number of cab steps: 2.; Cab suspension mechanical; LED head lights; DAF Corner View.

Optional

07017 Day Cab	00936 Auxiliary LED lights on cab roof, prepared
06244 Sleeper High Cab	01836 LED Skylights
02889 Chassis front execution: no bottom plate	00949 LED Skylights; aux. LED lights on cab rf, prepared
02952 Chassis front execution: bottom plate aero	01925 Two LED work lamps for cab rear wall
03353 Chassis front execution: protruding	01891 Hazard beacons on cab front, prepared
07586 Chassis front execution: robust	06629 Two hazard beacon lights
01226 Cab suspension air	03232 Front windscreen with solar control foil
03358 External sun visor	03317 Rear window: double glass
06790 Aluminium ladder 1-piece	07343 Kerb view window co-driver door
06791 Aluminium ladder 2-piece	01362 DAF Digital Vision System
03922 Fog lights front	

AERODYNAMICS

Optional

03793 No roof air deflector	03074 Side collars, both sides hinged
00010 Adj. roof air deflector short Sleeper High Cab	03419 Side collars, extended. One side hinged
00138 Adj. rf air defl.long mid >4m(!) Sleeper High Cab	03076 Side collars, extended. Both sides hinged
01552 Adj. roof air defl. long high >4m(!) Sleeper High	04146 Side skirts
02665 Adj. roof air defl. long mid XD Sleeper High Cab	01122 Side skirts
00094 Adj. roof air deflector for Day Cab	01126 Side skirts with bottom extensions
00021 Adj. roof air deflector long low Sleeper High Cab	01127 Side skirts with top extensions
04906 Side collars, one side hinged	01135 Side skirts with extensions at top and bottom

COLOURS

Cab colour E1980 Crystal White; Chassis colour grey.; Colour of bumper: Crystal White.

CAB INTERIOR

Cab interior trim colour: Luxury; Dashboard finish: Vision; Cab interior decoration: Hexagon; Driver seat: Comfort Air; Co-driver seat: cinema with fabric cover; Dashboard table; Storage compartment in centre; Automatic Temperature Control and airc; Auxiliary cab heater (water).

Optional

02353 Cab interior decoration: Argenta	03948 Single drawer
02350 Cab interior decoration: Natura	03954 Refrigerator
07733 Driver seat: Luxury Air	31364 Without feature: Lower bunk mattress
07736 Driver seat: Super Air	02854 Xtra Comfort mattress for lower bunk
07737 Driver seat: Xtra Leather Air	01775 Xtra Comfort mattress with topper for lower bunk
09541 Arm rest driver seat	01177 Luggage carrier
01740 Arm rest at both sides of the driver seat	01066 Upper bunk
02117 Third seat	06970 Automatic Cab Climate Control
02834 No dashboard table	

COMMUNICATION AND DRIVING MANAGEMENT

PACCAR Connect; Tachograph digital, Stoneridge 1C version G2V2; Speed limiter setting 85/90 km/h; DAF Infotainment Luxury with Luxury speakers; Adaptive Cruise Control with FCW and AEBS-3.

Optional

09681 Preparation for Maut	01915 DAF Infotainment System: Luxury Plus
06211 DAF Infotainment System with FM/DAB/DAB+ radio	16155 Audio equipment, makes and types
03470 DAF Infotainment System: Exclusive, prepared	

SAFETY AND SECURITY

Lane Departure Warning System; Vehicle Stability Control (VSC); Basic engine immobiliser system; DAF Side & Turn Assist.

Optional

08631 Air bag (driver) and 2 seat belt tensioners	06410 Safe Load Pass preparation
02178 Main switch with second control in the cab	00795 Safety regulations EC ADR

SUSPENSION AND AXLES

Front: 8.00 t, parabolic, 163N; Rear axle load 13.00 t; Rear: air suspension, SR1344; No lifting device.

Optional

01769 Front axle load 7.50 t	04057 Rear axle HR1356
06257 Front axle load 9.00 t	04588 Rear axle SR1347
04647 Front springs air	08191 Axle load monitoring

WHEELS AND TYRES

Driven rear axle(s): 315/70R22.5; F1,315/70R22.5GO FMXSE 156/150 L Steering BBA 3P; R1,315/70R22.5GO FMXDE 154/150 L Traction BBA 3P.

Optional

16152 Tyre makes and types

DRIVELINE

Engine MX-11, multi torque 6 cylinder diesel engine, 10.8 litres. Output 220 kW (299 hp) at 1600 rpm. Max. torque 1450 Nm at 900-1400 rpm.; Exhaust emission Euro 6; Eco fuel; 12-speed TraXon 12TX1810 OD, 12.92-0.77; Gearbox ratio 12.92-0.77; Rear axle ratio 3.08; ASR.

Optional

07110 Eco performance	08371 Long Combination Vehicle (LCV)
02313 Gearbox direct drive	09638 Off-road applications
01514 Urge-to-move	01498 Off-road applications with Rock-free function
07101 Standard transport, Lite version	02843 Mechanical differential lock
09637 Liquid transport	

BRAKE SYSTEM

MX Engine Brake; Ventilated disc brakes front and rear. Dual circuit air system with electronic control (EBS). Engine driven, water cooled air compressor with automatic air heated dryer..

Optional

09920 No MX Engine Brake	01497 Park brake control pneumatic with spoken warning
02715 ZF Intarder	
01572 Park brake control electro-pneumatic	04901 Spring brake cylinders on the first front axle

CHASSIS

Wheelbase 3.80 m / rear overhang 0.99 m; Side member height 260 mm; Standard component location; 430 l alu fuel tank LH, height 620 mm; Tank for AdBlue® 40 l, on left-hand mudguard; Front underrun protection (FUP); Catwalk with step; Rear mudguards; Spray suppression; Work lamp LED.

Optional

06641 Free space left+right behind SCR/DPF	02883 Component-free right-hand side, 1900 mm
08740 Free space between front and rear axle	16157 Fuel tanks, material and sizes
07007 Component-free right hand side, 1500 mm	07071 Spare wheel carrier right-hand side
03598 Component-free right hand side, 1700 mm	03323 Rear light with LEDs

DRAWBAR AND TRAILER EQUIPMENT

JOST JSK36DV pressed steel 205+40mm; Pneumatic trailer connection C-type; Electric connection 24 V / 2x7 pins.

Optional

03178 Towing hook D= 4.3	16151 5th wheel makes and heights
04359 Lead-up ramps	

BODIES AND PREPARATIONS FOR BODYING

Optional

02811 Tail lift connection Anderson	02812 Tail lift connection REMA
--	--

POWER TAKE-OFF (PTO)

Optional

16148 PTO types and positions

24V POWER SUPPLY

Alternator 110 A, batteries 2x 175 Ah..

Optional

04492 Alternator 130 A	07671 Batteries 2x210Ah AGM C-type
08775 Alternator 150 A	
01257 Batteries 2x140Ah	06440 Batteries 2x230Ah

GVM AND GCM

Chassis weight related technical GVM max 20500 kg; Driveline related max GCM 40000 kg class 3.

APPLICATION CONDITIONS

Air intake front.

Optional

08400 Silent mode	06614 Anti-dust blow-up shield
02260 Extra cab insulation	06620 Anti-dust blow-up shield + bugscreen
03648 Cyclonic air intake high	

SERVICE AND MAINTENANCE

Standard Warranty takes care of 1 year complete vehicle as supplied by the OEM (excl. real wear parts), 2nd year driveline and 1st year breakdown.; ITS service.

Optional

08311 Service interval extended
--

VEHICLE DELIVERY

Minimum toolkit.

Optional

07569 Lifting jack

OPTION PACKAGES

Optional

17448 Safety pack	17595 Executive Pack XD/XF
--------------------------	-----------------------------------

XD 300

FT 4X2 Tractor

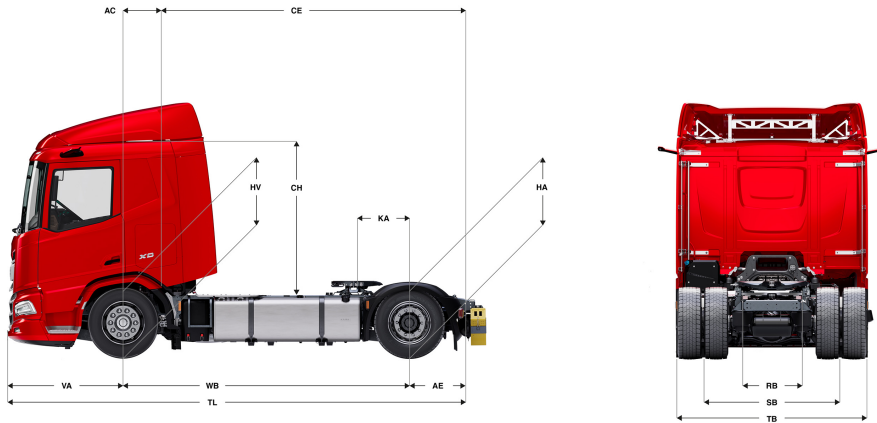

	Wheelbase - AE		Unladen weight ¹⁾			Gross Carrying Capacity			Variable dimensions								
	WB	AE ⁵⁾	Front	Rear	Total	Front	Rear	Total	AC	CE	CH	KA ⁶⁾	TL	HA ⁷⁾	HA ⁸⁾	TK ⁹⁾	TW ¹⁰⁾
DAY CAB	3,25	0,75	4942	1974	6916	3058	9526	11084	0,50	3,50	2,82	0,47	5,53	0,97	0,94	12,08	13,43
	3,60	0,99	4898	2156	7054	3102	9344	10946	0,50	4,09	2,82	0,47	6,12	0,97	0,94	12,98	14,35
	3,80	0,99	4906	2043	6949	3094	9457	11051	0,50	4,29	2,82	0,77	6,32	0,97	0,94	13,50	14,88
	4,00	0,99	4962	2115	7078	3038	9385	10922	0,50	4,49	2,82	0,77	6,52	0,97	0,94	14,01	15,41
SLEEPER CAB	WB	AE ⁵⁾	Front	Rear	Total	Front	Rear	Total	AC	CE	CH	KA ⁶⁾	TL	HA ⁷⁾	HA ⁸⁾	TK ⁹⁾	TW ¹⁰⁾
	3,60	0,99	4975	2068	7042	3025	9432	10958	0,83	3,76	2,82	0,47	6,12	0,97	0,94	12,98	14,35
	3,80	0,99	5037	2003	7040	2963	9497	10960	0,83	3,96	2,82	0,77	6,32	0,97	0,94	13,50	14,88
	4,00	0,99	5096	2073	7168	2904	9427	10832	0,83	4,16	2,82	0,77	6,52	0,97	0,94	14,01	15,41
SLEEPER HIGH CAB	WB	AE ⁵⁾	Front	Rear	Total	Front	Rear	Total	AC	CE	CH	KA ⁶⁾	TL	HA ⁷⁾	HA ⁸⁾	TK ⁹⁾	TW ¹⁰⁾
	3,60	0,99	4944	2063	7007	3056	9437	10993	0,83	3,76	2,68	0,47	6,12	0,97	0,94	12,98	14,35
	3,80	0,99	5006	1998	7005	2994	9502	10995	0,83	3,96	2,68	0,77	6,32	0,97	0,94	13,50	14,88
	4,00	0,99	5065	2068	7133	2935	9432	10867	0,83	4,16	2,68	0,77	6,52	0,97	0,94	14,01	15,41

OTHER DIMENSIONS	VA: 1,53	HV ¹¹⁾ : 0,96	HV ¹²⁾ : 0,87	RB: 0,79	SB: 1,82	TB ¹³⁾ : 2,48
------------------	----------	--------------------------	--------------------------	----------	----------	--------------------------

1) GVM in conformity with registration documents.
 2) GCM in conformity with registration documents.
 3) Axle load with standard tyre size.
 4) Chassis and cab weight calculated with: Standard specification items only with 430 litres of fuel, 40 litres of AdBlue® and driver of 90 kg, tolerance ± 3%. Changing of the specification can have major impact on vehicle weight.
 5) Other AE dimensions may be available for shown WB.
 6) Calculate customer specific KA with TOPEC.

7) Unladen height at centre of driven axle(s).
 8) Laden height at centre of driven axle(s).
 9) TK = turning circle between kerbs.
 10) TW = turning circle between walls.
 11) Unladen height at centre of front axle(s).
 12) Laden height at centre of front axle(s).
 13) TB is overall width at rear. (At centre of front axle 255).

Depending on the vehicle configuration a specific option may not be possible. The availability and specification of this vehicle may differ per country. For further information please contact the DAF organisation. Pictures and technical illustrations are not binding in detail and can differ from the standard specification. Subject to modification without prior notice.