

Specification sheet

XD 300

FAN 6X2 Rigid

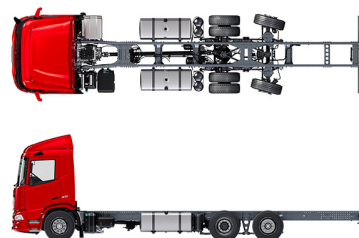

ENGINES

- XD NewGen 300 MX-11 (220 kW / 299 hp)
- XD NewGen 340 MX-11 (251 kW / 341 hp)
- XD NewGen 370 MX-11 (270 kW / 367 hp)
- XD NewGen 410 MX-11 (300 kW / 408 hp)
- XD NewGen 450 MX-11 (330 kW / 449 hp)

GVM¹⁾

- 26000 kg
- Max. front 8000 kg
- Max. rear 19000 kg

GCM²⁾

- 38000 kg

016F0121NAAA - 202513C - 06-12-2024

DAF Trucks Ltd, UK, Haddenham, HP17 8LJ, www.daf.co.uk

CAB EXTERIOR

Luxurious Day Cab with unrivalled aerodynamics for fuel efficient driving and low CO2 emissions. The huge and deep frontscreen, curved at the sides combined with large side windows offer an unsurpassed direct view for the driver, to enhance road safety. Cab length: 2030 mm; cab width: 2500 mm. Number of cab entrance steps: 2.; Cab suspension mechanical; LED head lights; DAF Corner View.

Optional

07018 Sleeper Cab	01836 LED Skylights
06244 Sleeper High Cab	00949 LED Skylights; aux. LED lights on cab rf, prepared
02889 Chassis front execution: no bottom plate	01925 Two LED work lamps for cab rear wall
02952 Chassis front execution: bottom plate aero	01891 Hazard beacons on cab front, prepared
03353 Chassis front execution: protruding	06629 Two hazard beacon lights
07586 Chassis front execution: robust	03232 Front windscreen with solar control foil
01226 Cab suspension air	03317 Rear window: double glass
03358 External sun visor	07343 Kerb view window co-driver door
03922 Fog lights front	01362 DAF Digital Vision System
00936 Auxiliary LED lights on cab roof, prepared	

AERODYNAMICS

Optional

03846 No roof air deflector	02662 Adj. roof air defl. long mid XD Sleeper High Cab
00008 Adj. roof air deflector short Sleeper High Cab	00097 Adj. roof air deflector for Sleeper Cab
00124 Adj. rf air defl.long mid >4m(!) Sleeper High Cab	00020 Adj. roof air deflector long low Sleeper High Cab
01538 Adj. roof air defl. long high >4m(!) Sleeper High	

COLOURS

Cab colour E1980 Crystal White; Chassis colour grey.; Colour of bumper: Crystal White.

CAB INTERIOR

Cab interior trim colour: Luxury; Dashboard finish: Vision; Cab interior decoration: Hexagon; Driver seat: Comfort Air; Co-driver seat: cinema with fabric cover; No dashboard table; Storage compartment in centre; Automatic Temperature Control and airco; No auxiliary cab heater.

Optional

02354 Steering wheel with silver accents	02117 Third seat
02355 Steering wheel, leather	02837 Dashboard table
02353 Cab interior decoration: Argenta	03948 Single drawer
02350 Cab interior decoration: Natura	03954 Refrigerator
07733 Driver seat: Luxury Air	02838 Foam mattress for lower bunk
07736 Driver seat: Super Air	02854 Xtra Comfort mattress for lower bunk
07737 Driver seat: Xtra Leather Air	01775 Xtra Comfort mattress with topper for lower bunk
09541 Arm rest driver seat	06970 Automatic Cab Climate Control
01740 Arm rest at both sides of the driver seat	

COMMUNICATION AND DRIVING MANAGEMENT

PACCAR Connect; Tachograph digital, Stoneridge 1C version G2V2; Speed limiter setting 85/90 km/h; DAF Infotainment Luxury with Luxury speakers; Adaptive Cruise Control with FCW and AEBS-3; Driver Performance Assistant.

Optional

09681 Preparation for Maut	01915 DAF Infotainment System: Luxury Plus
06211 DAF Infotainment System with FM/DAB/DAB+ radio	06990 No Predictive Cruise Control
03470 DAF Infotainment System: Exclusive, prepared	

SAFETY AND SECURITY

Lane Departure Warning System; Vehicle Stability Control (VSC); Basic engine immobiliser system; No EC-ADR packages; DAF Side & Turn Assist.

Optional

08631 Air bag (driver) and 2 seat belt tensioners	00795 Safety regulations EC ADR
06410 Safe Load Pass preparation	

SUSPENSION AND AXLES

Front: 8.00 t, parabolic, 163N; Rear axle load 13.00 t; Rear: 20.00 t, air suspension, SR1344; Trailing axle load 8.0t; Lifting device.

Optional

06257 Front axle load 9.00 t	04057 Rear axle HR1356
06095 Front axle load 10.00 t	04588 Rear axle SR1347
04647 Front springs air	08191 Axle load monitoring

WHEELS AND TYRES

Driven rear axle(s): 315/70R22.5; F1,315/70R22.5GO FMXSE 156/150 L Steering BBA 3P; R1,315/70R22.5GO FMXDE 154/150 L Traction BBA 3P; R2,315/70R22.5GO FMXSE 156/150 L Steering BBA 3P.

Optional

16152 Tyre makes and types

DRIVELINE

Engine MX-11, multi torque 6 cylinder diesel engine, 10.8 litres. Output 220 kW (299 hp) at 1600 rpm. Max. torque 1450 Nm at 900-1400 rpm.; Exhaust emission Euro 6; Eco fuel; 12-speed TraXon 12TX1810 OD, 12.92-0.77; Gearbox ratio 12.92-0.77; Rear axle ratio 3.08.

Optional

07110 Eco performance	08371 Long Combination Vehicle (LCV)
09889 Automatic gearbox, 6 speeds	09638 Off-road applications
02313 Gearbox direct drive	01498 Off-road applications with Rock-free function
01514 Urge-to-move	08370 Refuse collection
31014 Without feature: Manoeuvring mode	06654 No gearbox software setting
07101 Standard transport, Lite version	02843 Mechanical differential lock
09637 Liquid transport	

BRAKE SYSTEM

Exhaust brake; Ventilated disc brakes front and rear. Dual circuit air system with electronic control (EBS).Engine driven, water cooled aire compressor with automatic air heated dryer..

Optional

09921 MX Engine Brake	01497 Park brake control pneumatic with spoken warning
02715 ZF Intarder	
01572 Park brake control electro-pneumatic	04901 Spring brake cylinders on the first front axle
	00929 Driven rear axle with drum brakes

CHASSIS

Wheelbase 3.80 m / rear overhang 2.05 m; Side member height 260 mm; Standard component location; 340 l alu fuel tank LH, height 620 mm; Tank for AdBlue® 45 l, left-hand side chassis; Front underrun protection (FUP); Spray suppression.

Optional

02601 Side member height 310 mm	07071 Spare wheel carrier right-hand side
08641 Air tanks aluminium	03323 Rear light with LEDs
16157 Fuel tanks, material and sizes	

DRAWBAR AND TRAILER EQUIPMENT

Closing member D-value = 0kN.

Optional

07033 Trailer coupling Ringfeder D=13.7	08027 Trailer coupling Rockinger D=20.0
07034 Trailer coupling Ringfeder D=20.0	04659 Trailer cable EBS
08026 Trailer coupling Rockinger D=13.0	

BODIES AND PREPARATIONS FOR BODYING

Application connector chassis.

Optional

09421 Additional spare wiring	09201 Chassis preparation for BDF
02950 Application connector for hydraulic platform	09208 Chassis preparation for BDF Multi system
09240 Application connector for refuse collector	08121 Tail lift application

POWER TAKE-OFF (PTO)

Optional

16148 PTO types and positions

24V POWER SUPPLY

Alternator 130 A, batteries 2x 140 Ah..

Optional

08775 Alternator 150 A	07671 Batteries 2x210Ah AGM C-type
08797 Batteries 2x175Ah	06440 Batteries 2x230Ah

GVM AND GCM

Chassis weight related technical GVM max 27000 kg; Driveline related max GCM 38000 kg class 2.

Optional

04330 Driveline related max GCM 27000 kg class 2	03675 Driveline related max GCM 50000 kg class 3
00710 Driveline related max GCM 28000 kg class 3	00939 Driveline related max GCM 56000 kg class 2
00209 Driveline related max GCM 40000 kg class 3	00818 Driveline related max GCM 60000 kg class 3
03673 Driveline related max GCM 44000 kg class 2	

APPLICATION CONDITIONS

Air intake front.

Optional

08400 Silent mode	06614 Anti-dust blow-up shield
02260 Extra cab insulation	06620 Anti-dust blow-up shield + bugscreen
03648 Cyclonic air intake high	

SERVICE AND MAINTENANCE

Standard Warranty takes care of 1 year complete vehicle as supplied by the OEM (excl. real wear parts), 2nd year driveline and 1st year breakdown.; ITS service.

Optional

08311 Service interval extended
--

VEHICLE DELIVERY

Minimum toolkit.

Optional

07569 Lifting jack

OPTION PACKAGES

Optional

17448 Safety pack	17595 Executive Pack XD/XF
--------------------------	-----------------------------------

Go to [DAF.com](https://www.daf.com) to configure your own perfect DAF.

XD 300

FAN 6X2 Rigid

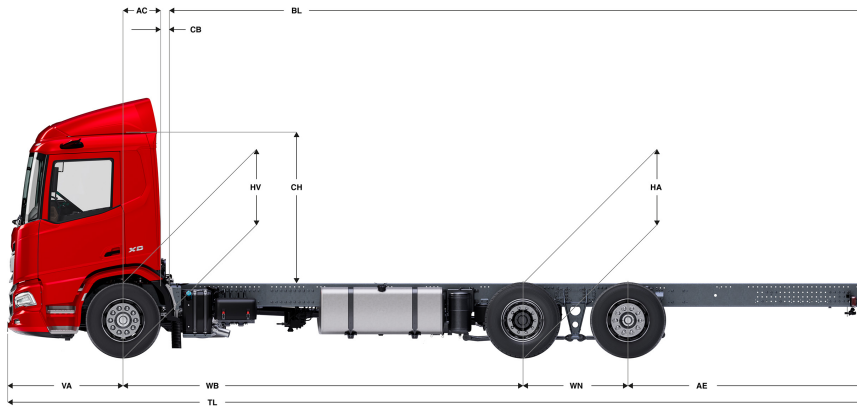

	Wheelbase - AE		Unladen weight ⁹⁾			Gross Carrying Capacity			Variable dimensions									
	WB	AE ⁵⁾	Front	Rear	Total	Front	Rear	Total	AC	CB ⁶⁾	CH	BL ⁷⁾	BL	TL	HA ⁸⁾	HA ⁹⁾	TK ¹⁰⁾	TW ¹¹⁾
DAY CAB	3,80	2,05	4857	2996	7853	3143	16004	18147	0,50	0,07	2,82	6,11	6,11	8,78	0,97	0,94	13,50	14,88
	4,00	2,40	4898	3182	8080	3102	15818	17920	0,50	0,25	2,77	6,08	6,08	9,33	1,02	0,99	14,01	15,41
	4,20	2,40	4850	3091	7942	3150	15909	18058	0,50	0,07	2,82	6,77	6,77	9,53	0,97	0,94	14,53	15,94
	4,40	2,55	4844	3129	7973	3156	15871	18027	0,50	0,07	2,82	7,09	7,09	9,88	0,97	0,94	15,05	16,46
	4,60	2,55	4901	3246	8147	3099	15754	17853	0,50	0,07	2,82	7,44	7,44	10,08	0,97	0,94	15,57	16,99
	4,80	2,70	4881	3274	8155	3119	15726	17845	0,50	0,07	2,82	7,75	7,75	10,43	0,97	0,94	16,09	17,52
	5,05	2,90	4872	3321	8192	3128	15679	17808	0,50	0,07	2,82	8,17	8,17	10,88	0,97	0,94	16,74	18,18
	5,30	3,15	4848	3337	8185	3152	15663	17815	0,50	0,07	2,82	8,56	8,56	11,38	0,97	0,94	17,40	18,84
5,60	3,15	4907	3483	8390	3093	15517	17610	0,50	0,07	2,77	9,09	9,09	11,68	1,02	0,99	18,18	19,64	
6,10	2,90	4939	3479	8418	3061	15521	17582	0,50	0,07	2,77	9,94	9,94	11,93	1,02	1,00	19,49	20,96	
SLEEPER CAB	WB	AE ⁵⁾	Front	Rear	Total	Front	Rear	Total	AC	CB ⁶⁾	CH	BL ⁷⁾	BL	TL	HA ⁸⁾	HA ⁹⁾	TK ¹⁰⁾	TW ¹¹⁾
	3,80	2,05	4857	2996	7853	3143	16004	18147	0,50	0,07	2,82	6,11	6,11	8,78	0,97	0,94	13,50	14,88
	4,00	2,40	4898	3182	8080	3102	15818	17920	0,50	0,25	2,77	6,08	6,08	9,33	1,02	0,99	14,01	15,41
	4,20	2,40	4976	3095	8071	3024	15905	17929	0,83	0,07	2,82	6,15	6,15	9,53	0,97	0,94	14,53	15,94
	4,40	2,55	4969	3133	8102	3031	15867	17898	0,83	0,07	2,82	6,49	6,49	9,88	0,97	0,94	15,05	16,46
	4,60	2,55	5026	3250	8276	2974	15750	17724	0,83	0,07	2,82	6,83	6,83	10,08	0,97	0,94	15,57	16,99
	4,80	2,70	5006	3278	8284	2994	15722	17716	0,83	0,07	2,82	7,16	7,16	10,43	0,97	0,94	16,09	17,52
	5,05	2,90	4997	3324	8322	3003	15676	17678	0,83	0,07	2,82	7,56	7,56	10,88	0,97	0,94	16,74	18,18
5,30	3,15	4974	3341	8315	3026	15659	17685	0,83	0,07	2,82	7,97	7,97	11,38	0,97	0,94	17,40	18,84	
5,60	3,15	5033	3486	8519	2967	15514	17481	0,83	0,07	2,77	8,50	8,50	11,68	1,02	0,99	18,18	19,64	
6,10	2,90	5065	3482	8548	2935	15518	17452	0,83	0,07	2,77	9,36	9,36	11,93	1,02	0,99	19,49	20,96	
SLEEPER HIGH CAB	WB	AE ⁵⁾	Front	Rear	Total	Front	Rear	Total	AC	CB ⁶⁾	CH	BL ⁷⁾	BL	TL	HA ⁸⁾	HA ⁹⁾	TK ¹⁰⁾	TW ¹¹⁾
	3,80	2,05	4857	2996	7853	3143	16004	18147	0,50	0,07	2,82	6,11	6,11	8,78	0,97	0,94	13,50	14,88
	4,00	2,40	4898	3182	8080	3102	15818	17920	0,50	0,25	2,77	6,08	6,08	9,33	1,02	0,99	14,01	15,41
	4,20	2,40	4945	3091	8036	3055	15909	17964	0,83	0,07	2,68	6,14	6,14	9,53	0,97	0,94	14,53	15,94
	4,40	2,55	4938	3128	8067	3062	15872	17933	0,83	0,07	2,68	6,47	6,47	9,88	0,97	0,94	15,05	16,46
	4,60	2,55	4996	3245	8241	3004	15755	17759	0,83	0,07	2,68	6,83	6,83	10,08	0,97	0,94	15,57	16,99
	4,80	2,70	4976	3273	8249	3024	15727	17751	0,83	0,07	2,68	7,14	7,14	10,43	0,97	0,94	16,09	17,52
	5,05	2,90	4967	3320	8287	3033	15680	17713	0,83	0,07	2,68	7,56	7,56	10,88	0,97	0,94	16,74	18,18
5,30	3,15	4943	3336	8279	3057	15664	17721	0,83	0,07	2,68	7,96	7,96	11,38	0,97	0,94	17,40	18,84	
5,60	3,15	5003	3482	8484	2997	15518	17516	0,83	0,07	2,63	8,48	8,48	11,68	1,02	0,99	18,18	19,64	
6,10	2,90	5035	3478	8512	2965	15522	17488	0,83	0,07	2,63	9,34	9,34	11,93	1,02	0,99	19,49	20,96	

OTHER DIMENSIONS VA: 1,53 WN: 1,40 HV¹²⁾: 0,97 HV¹³⁾: 0,93 RB: 0,79 SB: 1,82 TB¹⁴⁾: 2,48

1) GVM in conformity with registration documents.
 2) GCM in conformity with registration documents.
 3) Axle load with standard tyre size.
 4) Chassis and cab weight calculated with: Standard specification items only with 340 litres of fuel, 45 litres of AdBlue® and driver of 90 kg, tolerance ± 3%. Changing of the specification can have major impact on vehicle weight.
 5) Other AE dimensions may be available for shown WB. Modify rear overhang to the calculated body length.
 6) CB is based on standard air intake and/or exhaust.
 7) Calculate customer specific body length with TOPEC. Body lengths shown based on evenly distributed load at max axle load.

8) Unladen height at centre of driven axle (trailing axle down).
 9) Laden height at centre of driven axle(s).
 10) TK = turning circle between kerbs.
 11) TW = turning circle between walls.
 12) Unladen height at centre of front axle(s).
 13) Laden height at centre of front axle(s).
 14) TB is overall width at rear. (At centre of front axle 255).

Depending on the vehicle configuration a specific option may not be possible. The availability and specification of this vehicle may differ per country. For further information please contact the DAF organisation. Pictures and technical illustrations are not binding in detail and can differ from the standard specification. Subject to modification without prior notice.