

Specification sheet

XD 300

FAR 6X2 Rigid, single mounted trailing axle

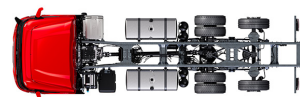

ENGINES

- XD NewGen 300 MX-11 (220 kW / 299 hp)
- XD NewGen 340 MX-11 (251 kW / 341 hp)
- XD NewGen 370 MX-11 (270 kW / 367 hp)
- XD NewGen 410 MX-11 (300 kW / 408 hp)
- XD NewGen 450 MX-11 (330 kW / 449 hp)

GVM¹⁾

- 26000 kg
- Max. front 8000 kg
- Max. rear 19000 kg

GCM²⁾

- 38000 kg

016F0121CAAA - 202513C - 06-12-2024

DAF Trucks Ltd, UK, Haddenham, HP17 8LJ, www.daf.co.uk

CAB EXTERIOR

Luxurious Day Cab with unrivalled aerodynamics for fuel efficient driving and low CO2 emissions. The huge and deep frontscreen, curved at the sides combined with large side windows offer an unsurpassed direct view for the driver, to enhance road safety. Cab length: 2030 mm; cab width: 2500 mm. Number of cab entrance steps: 2.; Cab suspension mechanical; LED head lights; DAF Corner View.

Optional

| | |
|---|---|
| 07018 Sleeper Cab | 01836 LED Skylights |
| 06244 Sleeper High Cab | 00949 LED Skylights; aux. LED lights on cab rf, prepared |
| 02889 Chassis front execution: no bottom plate | 01925 Two LED work lamps for cab rear wall |
| 02952 Chassis front execution: bottom plate aero | 01891 Hazard beacons on cab front, prepared |
| 03353 Chassis front execution: protruding | 06629 Two hazard beacon lights |
| 07586 Chassis front execution: robust | 03232 Front windscreen with solar control foil |
| 01226 Cab suspension air | 03317 Rear window: double glass |
| 03358 External sun visor | 07343 Kerb view window co-driver door |
| 03922 Fog lights front | 01362 DAF Digital Vision System |
| 00936 Auxiliary LED lights on cab roof, prepared | |

AERODYNAMICS

Optional

| | |
|--|--|
| 03846 No roof air deflector | 02662 Adj. roof air defl. long mid XD Sleeper High Cab |
| 00008 Adj. roof air deflector short Sleeper High Cab | 00097 Adj. roof air deflector for Sleeper Cab |
| 00124 Adj. rf air defl.long mid >4m(!) Sleeper High Cab | 00020 Adj. roof air deflector long low Sleeper High Cab |
| 01538 Adj. roof air defl. long high >4m(!) Sleeper High | |

COLOURS

Cab colour E1980 Crystal White; Chassis colour grey.; Colour of bumper: Crystal White.

CAB INTERIOR

Cab interior trim colour: Luxury; Dashboard finish: Vision; Cab interior decoration: Hexagon; Driver seat: Comfort Air; Co-driver seat: cinema with fabric cover; No dashboard table; Storage compartment in centre; Automatic Temperature Control and airco; No auxiliary cab heater.

Optional

| | |
|--|---|
| 02354 Steering wheel with silver accents | 02117 Third seat |
| 02355 Steering wheel, leather | 02837 Dashboard table |
| 02353 Cab interior decoration: Argenta | 03948 Single drawer |
| 02350 Cab interior decoration: Natura | 03954 Refrigerator |
| 07733 Driver seat: Luxury Air | 02838 Foam mattress for lower bunk |
| 07736 Driver seat: Super Air | 02854 Xtra Comfort mattress for lower bunk |
| 07737 Driver seat: Xtra Leather Air | 01775 Xtra Comfort mattress with topper for lower bunk |
| 09541 Arm rest driver seat | 06970 Automatic Cab Climate Control |
| 01740 Arm rest at both sides of the driver seat | |

COMMUNICATION AND DRIVING MANAGEMENT

PACCAR Connect; Tachograph digital, Stoneridge 1C version G2V2; Speed limiter setting 85/90 km/h; DAF Infotainment Luxury with Luxury speakers; Adaptive Cruise Control with FCW and AEBS-3; Driver Performance Assistant.

Optional

| | |
|---|---|
| 09681 Preparation for Maut | 03470 DAF Infotainment System: Exclusive, prepared |
| 06211 DAF Infotainment System with FM/DAB/DAB+ radio | 01915 DAF Infotainment System: Luxury Plus |

SAFETY AND SECURITY

Lane Departure Warning System; Vehicle Stability Control (VSC); Basic engine immobiliser system; No EC-ADR packages; DAF Side & Turn Assist.

Optional

| | |
|--|--|
| 08631 Air bag (driver) and 2 seat belt tensioners | 00795 Safety regulations EC ADR |
| 06410 Safe Load Pass preparation | |

SUSPENSION AND AXLES

Front: 8.00 t, parabolic, 163N; Rear axle load 12.00 t; Rear: 19.50 t, air suspension, SR1344; Trailing axle load 7.5t; Lifting device.

Optional

| | |
|--------------------------------------|-------------------------------------|
| 06257 Front axle load 9.00 t | 04588 Rear axle SR1347 |
| 06095 Front axle load 10.00 t | 03040 Rear axle load 11.50 t |
| 04647 Front springs air | 08191 Axle load monitoring |
| 04057 Rear axle HR1356 | |

WHEELS AND TYRES

Driven rear axle(s): 315/70R22.5; F1,315/70R22.5GO FMXSE 156/150 L Steering BBA 3P; R1,315/70R22.5GO FMXDE 154/150 L Traction BBA 3P; R2,315/70R22.5GO FMXSE 156/150 L Steering BBA 3P.

Optional

| |
|-----------------------------------|
| 16152 Tyre makes and types |
|-----------------------------------|

DRIVELINE

Engine MX-11, multi torque 6 cylinder diesel engine, 10.8 litres. Output 220 kW (299 hp) at 1600 rpm. Max. torque 1450 Nm at 900-1400 rpm.; Exhaust emission Euro 6; Eco fuel; 12-speed TraXon 12TX1810 OD, 12.92-0.77; Gearbox ratio 12.92-0.77; Rear axle ratio 3.08.

Optional

| | |
|---|--|
| 07110 Eco performance | 08371 Long Combination Vehicle (LCV) |
| 02313 Gearbox direct drive | 09638 Off-road applications |
| 01514 Urge-to-move | 01498 Off-road applications with Rock-free function |
| 07101 Standard transport, Lite version | 02843 Mechanical differential lock |
| 09637 Liquid transport | |

BRAKE SYSTEM

Exhaust brake; Ventilated disc brakes front and rear. Dual circuit air system with electronic control (EBS).Engine driven, water cooled air compressor with automatic air heated dryer..

Optional

| | |
|---|---|
| 09921 MX Engine Brake | 01497 Park brake control pneumatic with spoken warning |
| 02715 ZF Intarder | 04901 Spring brake cylinders on the first front axle |
| 01572 Park brake control electro-pneumatic | 00929 Driven rear axle with drum brakes |

CHASSIS

Wheelbase 3.80 m / rear overhang 2.05 m; Side member height 260 mm; Standard component location; 340 l alu fuel tank LH, height 620 mm; Tank for AdBlue® 45 l, left-hand side chassis; Front underrun protection (FUP); Spray suppression.

Optional

| | |
|---|--|
| 02601 Side member height 310 mm | 07071 Spare wheel carrier right-hand side |
| 08641 Air tanks aluminium | 03323 Rear light with LEDs |
| 16157 Fuel tanks, material and sizes | |

DRAWBAR AND TRAILER EQUIPMENT

Closing member D-value = 0kN.

Optional

| | |
|--|--|
| 07033 Trailer coupling Ringfeder D=13.7 | 08027 Trailer coupling Rockinger D=20.0 |
| 07034 Trailer coupling Ringfeder D=20.0 | 04659 Trailer cable EBS |
| 08026 Trailer coupling Rockinger D=13.0 | |

BODIES AND PREPARATIONS FOR BODYING

Application connector chassis.

Optional

| | |
|--|---|
| 09421 Additional spare wiring | 09208 Chassis preparation for BDF Multi system |
| 09201 Chassis preparation for BDF | 08121 Tail lift application |

POWER TAKE-OFF (PTO)

Optional

| |
|--------------------------------------|
| 16148 PTO types and positions |
|--------------------------------------|

24V POWER SUPPLY

Alternator 110 A, batteries 2x 140 Ah..

Optional

| | |
|--------------------------------|---|
| 04492 Alternator 130 A | 07671 Batteries 2x210Ah AGM C-type |
| 08775 Alternator 150 A | 06440 Batteries 2x230Ah |
| 08797 Batteries 2x175Ah | |

GVM AND GCM

Chassis weight related technical GVM max 27000 kg; Driveline related max GCM 38000 kg class 2.

Optional

| | |
|---|---|
| 00209 Driveline related max GCM 40000 kg class 3 | 00939 Driveline related max GCM 56000 kg class 2 |
| 03673 Driveline related max GCM 44000 kg class 2 | 00818 Driveline related max GCM 60000 kg class 3 |
| 03675 Driveline related max GCM 50000 kg class 3 | |

APPLICATION CONDITIONS

Air intake front.

Optional

| | |
|---------------------------------------|---|
| 02260 Extra cab insulation | 06614 Anti-dust blow-up shield |
| 03648 Cyclonic air intake high | 06620 Anti-dust blow-up shield + bugscreen |

SERVICE AND MAINTENANCE

Standard Warranty takes care of 1 year complete vehicle as supplied by the OEM (excl. real wear parts), 2nd year driveline and 1st year breakdown.; ITS service.

Optional

| |
|--|
| 08311 Service interval extended |
|--|

VEHICLE DELIVERY

Minimum toolkit.

Optional

| |
|---------------------------|
| 07569 Lifting jack |
|---------------------------|

OPTION PACKAGES

Optional

| | |
|--------------------------|-----------------------------------|
| 17448 Safety pack | 17595 Executive Pack XD/XF |
|--------------------------|-----------------------------------|

Go to [DAF.com](https://www.daf.com) to configure your own perfect DAF.

XD 300

FAR 6X2 Rigid, single mounted trailing axle

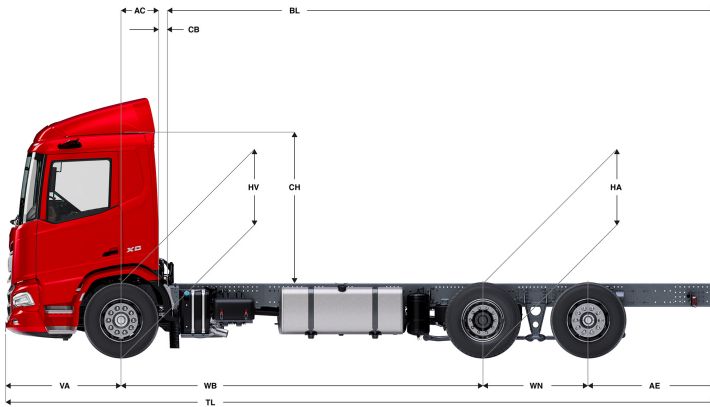

| | Wheelbase - AE | | Unladen weight ⁹⁾ | | | Gross Carrying Capacity | | | Variable dimensions | | | | | | | | | |
|------------------|----------------|------------------|------------------------------|------|-------|-------------------------|-------|-------|---------------------|------------------|------|------------------|-------|-------|------------------|------------------|-------------------|-------------------|
| | WB | AE ⁵⁾ | Front | Rear | Total | Front | Rear | Total | AC | CB ⁶⁾ | CH | BL ⁷⁾ | BL | TL | HA ⁸⁾ | HA ⁹⁾ | TK ¹⁰⁾ | TW ¹¹⁾ |
| DAY CAB | 3,80 | 2,05 | 4881 | 2983 | 7864 | 3119 | 16017 | 18136 | 0,50 | 0,07 | 2,82 | 6,13 | 6,13 | 8,78 | 0,97 | 0,94 | 14,93 | 16,34 |
| | 4,20 | 2,40 | 4864 | 3061 | 7926 | 3136 | 15939 | 18074 | 0,50 | 0,07 | 2,82 | 6,77 | 6,77 | 9,53 | 0,97 | 0,94 | 15,97 | 17,40 |
| | 4,40 | 2,55 | 4865 | 3118 | 7983 | 3135 | 15882 | 18017 | 0,50 | 0,07 | 2,82 | 7,10 | 7,10 | 9,88 | 0,97 | 0,94 | 16,49 | 17,92 |
| | 4,60 | 2,55 | 4922 | 3235 | 8157 | 3078 | 15765 | 17843 | 0,50 | 0,07 | 2,82 | 7,44 | 7,44 | 10,08 | 0,97 | 0,94 | 17,01 | 18,45 |
| | 4,80 | 2,70 | 4902 | 3264 | 8166 | 3098 | 15736 | 17834 | 0,50 | 0,07 | 2,82 | 7,77 | 7,77 | 10,43 | 0,97 | 0,94 | 17,53 | 18,98 |
| | 5,05 | 2,90 | 4890 | 3309 | 8199 | 3110 | 15691 | 17801 | 0,50 | 0,07 | 2,82 | 8,17 | 8,17 | 10,88 | 0,97 | 0,94 | 18,19 | 19,64 |
| | 5,30 | 2,90 | 4897 | 3327 | 8223 | 3103 | 15673 | 17777 | 0,50 | 0,07 | 2,82 | 8,59 | 8,59 | 11,13 | 0,97 | 0,94 | 18,84 | 20,30 |
| | 5,60 | 2,85 | 4943 | 3419 | 8363 | 3057 | 15581 | 17637 | 0,50 | 0,07 | 2,77 | 9,10 | 9,10 | 11,38 | 1,02 | 0,99 | 19,63 | 21,10 |
| 5,90 | 2,80 | 4955 | 3432 | 8387 | 3045 | 15568 | 17613 | 0,50 | 0,07 | 2,77 | 9,62 | 9,62 | 11,63 | 1,02 | 0,99 | 20,41 | 21,89 | |
| 6,10 | 2,80 | 4961 | 3445 | 8406 | 3039 | 15555 | 17594 | 0,50 | 0,07 | 2,77 | 9,95 | 9,95 | 11,83 | 1,02 | 0,99 | 20,94 | 22,42 | |
| SLEEPER CAB | 3,80 | 2,05 | 4881 | 2983 | 7864 | 3119 | 16017 | 18136 | 0,50 | 0,07 | 2,82 | 6,13 | 6,13 | 8,78 | 0,97 | 0,94 | 14,93 | 16,34 |
| | 4,20 | 2,40 | 4988 | 3065 | 8053 | 3012 | 15935 | 17947 | 0,83 | 0,07 | 2,82 | 6,17 | 6,17 | 9,53 | 0,97 | 0,94 | 15,97 | 17,40 |
| | 4,40 | 2,55 | 4989 | 3121 | 8111 | 3011 | 15879 | 17889 | 0,83 | 0,07 | 2,82 | 6,50 | 6,50 | 9,88 | 0,97 | 0,94 | 16,49 | 17,92 |
| | 4,60 | 2,55 | 5047 | 3238 | 8285 | 2953 | 15762 | 17715 | 0,83 | 0,07 | 2,82 | 6,85 | 6,85 | 10,08 | 0,97 | 0,94 | 17,01 | 18,45 |
| | 4,80 | 2,70 | 5026 | 3267 | 8294 | 2974 | 15733 | 17706 | 0,83 | 0,07 | 2,82 | 7,18 | 7,18 | 10,43 | 0,97 | 0,94 | 17,53 | 18,98 |
| | 5,05 | 2,90 | 5015 | 3312 | 8327 | 2985 | 15688 | 17673 | 0,83 | 0,07 | 2,82 | 7,58 | 7,58 | 10,88 | 0,97 | 0,94 | 18,19 | 19,64 |
| | 5,30 | 2,90 | 5022 | 3330 | 8351 | 2978 | 15670 | 17649 | 0,83 | 0,07 | 2,82 | 7,99 | 7,99 | 11,13 | 0,97 | 0,94 | 18,84 | 20,30 |
| | 5,60 | 2,85 | 5068 | 3422 | 8490 | 2932 | 15578 | 17510 | 0,83 | 0,07 | 2,77 | 8,51 | 8,51 | 11,38 | 1,02 | 0,99 | 19,63 | 21,10 |
| 5,90 | 2,80 | 5080 | 3435 | 8515 | 2920 | 15565 | 17485 | 0,83 | 0,07 | 2,77 | 9,03 | 9,03 | 11,63 | 1,02 | 0,99 | 20,41 | 21,89 | |
| 6,10 | 2,80 | 5086 | 3448 | 8534 | 2914 | 15552 | 17466 | 0,83 | 0,07 | 2,77 | 9,37 | 9,37 | 11,83 | 1,02 | 0,99 | 20,94 | 22,42 | |
| SLEEPER HIGH CAB | 3,80 | 2,05 | 4881 | 2983 | 7864 | 3119 | 16017 | 18136 | 0,50 | 0,07 | 2,82 | 6,13 | 6,13 | 8,78 | 0,97 | 0,94 | 14,93 | 16,34 |
| | 4,20 | 2,40 | 4958 | 3061 | 8018 | 3042 | 15939 | 17982 | 0,83 | 0,07 | 2,68 | 6,15 | 6,15 | 9,53 | 0,97 | 0,94 | 15,97 | 17,40 |
| | 4,40 | 2,55 | 4959 | 3117 | 8076 | 3041 | 15883 | 17924 | 0,83 | 0,07 | 2,68 | 6,49 | 6,49 | 9,88 | 0,97 | 0,94 | 16,49 | 17,92 |
| | 4,60 | 2,55 | 5016 | 3234 | 8250 | 2984 | 15766 | 17750 | 0,83 | 0,07 | 2,68 | 6,83 | 6,83 | 10,08 | 0,97 | 0,94 | 17,01 | 18,45 |
| | 4,80 | 2,70 | 4996 | 3263 | 8258 | 3004 | 15737 | 17742 | 0,83 | 0,07 | 2,68 | 7,16 | 7,16 | 10,43 | 0,97 | 0,94 | 17,53 | 18,98 |
| | 5,05 | 2,90 | 4984 | 3307 | 8291 | 3016 | 15693 | 17709 | 0,83 | 0,07 | 2,68 | 7,56 | 7,56 | 10,88 | 0,97 | 0,94 | 18,19 | 19,64 |
| | 5,30 | 2,90 | 4991 | 3325 | 8316 | 3009 | 15675 | 17684 | 0,83 | 0,07 | 2,68 | 7,98 | 7,98 | 11,13 | 0,97 | 0,94 | 18,84 | 20,30 |
| | 5,60 | 2,85 | 5037 | 3418 | 8455 | 2963 | 15582 | 17545 | 0,83 | 0,07 | 2,63 | 8,51 | 8,51 | 11,38 | 1,02 | 0,99 | 19,63 | 21,10 |
| 5,90 | 2,80 | 5050 | 3430 | 8480 | 2950 | 15570 | 17520 | 0,83 | 0,07 | 2,63 | 9,01 | 9,01 | 11,63 | 1,02 | 0,99 | 20,41 | 21,89 | |
| 6,10 | 2,80 | 5056 | 3443 | 8499 | 2944 | 15557 | 17501 | 0,83 | 0,07 | 2,63 | 9,35 | 9,35 | 11,83 | 1,02 | 0,99 | 20,94 | 22,42 | |

OTHER DIMENSIONS VA: 1,53 WN: 1,40 HV¹²⁾: 0,97 HV¹³⁾: 0,92 RB: 0,79 SB: 1,82 TB¹⁴⁾: 2,48

- GVM in conformity with registration documents.
- GCM in conformity with registration documents.
- Axle load with standard tyre size.
- Chassis and cab weight calculated with: Standard specification items only with 340 litres of fuel, 45 litres of AdBlue® and driver of 90 kg, tolerance ± 3%. Changing of the specification can have major impact on vehicle weight.
- Other AE dimensions may be available for shown WB. Modify rear overhang to the calculated body length.
- CB is based on standard air intake and/or exhaust.
- Calculate customer specific body length with TOPEC. Body lengths shown based on evenly distributed load at max axle load.
- Unladen height at centre of driven axle (trailing axle down).
- Laden height at centre of driven axle(s).
- TK = turning circle between kerbs.
- TW = turning circle between walls.
- Unladen height at centre of front axle(s).
- Laden height at centre of front axle(s).
- TB is overall width at rear. (At centre of front axle 255).

Depending on the vehicle configuration a specific option may not be possible. The availability and specification of this vehicle may differ per country. For further information please contact the DAF organisation. Pictures and technical illustrations are not binding in detail and can differ from the standard specification. Subject to modification without prior notice.