

Specification sheet

LF 150

FA 4X2 Rigid, 08t City



ENGINES

- LF 150 PX-4 (115 kW / 156 hp)
- LF 170 PX-4 (127 kW / 172 hp)

GVM¹⁾

7500 kg

GCM²⁾

7500 kg

Max. front 3600 kg

Max. rear 5000 kg

016F2602AAAA - 202217B - 14-01-2022

DAF Trucks Ltd, UK, Haddenham, HP17 8LJ, www.daf.co.uk

CAB EXTERIOR

Day Cab with steel bumper, tinted glass and electric window openers. Main mirrors and wide angle mirrors electrically heated. Cab width 2130 mm.; Electrically adjustable mirrors; Mirror brackets, body 2.50-2.60 m; Front view mirror.

Optional

| | | | |
|-------|--------------------------------------|-------|-----------------------------------|
| 01174 | External sun visor green translucent | 03605 | Mirror brackets, body 2.10-2.29 m |
| 07343 | Kerb view window co-driver door | 09282 | Mirror brackets, body 2.30-2.40 m |
| 00915 | Side no glass / rear single glass | 09283 | Mirror brackets, body 2.40-2.50 m |

AERODYNAMICS

Optional

| | | | |
|-------|-----------------------|-------|--------------------------|
| 09287 | Side collars prepared | 07112 | Side collars long (set) |
| 04906 | Side collars | 07093 | Side collars short (set) |

COLOURS

; Head lamp panel and bumper: Stone Grey; Cab steps and wing Stone Grey; Chassis colour grey..

Optional

| | | | |
|-------|--|-------|-------------------------|
| 06485 | Head lamp panel and bumper: cab colour | 16153 | Cab and chassis colours |
| 01109 | Cab steps and wing in cab colour | | |

CAB INTERIOR

Right-hand drive (RHD); Mechanically adjustable steering column; Driver seat: air suspended; Co-driver seat: fixed velour; Storage box on engine tunnel.

Optional

| | | | |
|-------|--|-------|--------------------------------|
| 01846 | Left-hand drive (LHD) | 02600 | Co-driver seat: air suspended |
| 09271 | Steering wheel, leather, colour black | 09106 | Dual mate seat, luxury version |
| 03516 | Pneumatically adjustable steering column | 00967 | Seat belts red |
| 00072 | Dual mate seat, velour | 02213 | Air conditioning |

COMMUNICATION AND DRIVING MANAGEMENT

FMS connector, prepared; Tachograph digital, Stoneridge 1C; Scale speedometer m/h + km/h; Adaptive Cruise Control with FCW and AEBS-3.

Optional

| | | | |
|-------|------------------------------|-------|----------------------------------|
| 02549 | Scale speedometer km/h | 16155 | Audio equipment, makes and types |
| 01936 | Scale speedometer km/h + m/h | 07261 | TruckPhone |

SAFETY AND SECURITY

Vehicle Stability Control (VSC); Basic engine immobiliser system.

Optional

| | | | |
|-------|---|-------|--|
| 08631 | Air bag (driver) and 2 seat belt tensioners | 06634 | Immobiliser 5 minutes and alarm (SCM BV03-B2) |
| 01725 | Reverse warning | | |
| 07414 | Reverse warning with self-adjusting volume | 06635 | Immobiliser 15 minutes and alarm (SCM BV03-B3) |
| 06633 | Immobiliser 5 minutes (SCM BV03-B1) | 16156 | EC-ADR packages |

SUSPENSION AND AXLES

Front: 3.60 t, parabolic, F36; Rear: 5.00 t, parabolic, SR5.10.

Optional

| | | | |
|-------|-------------------------------------|-------|------------------------------------|
| 07368 | Front springs parabolic, Heavy Duty | 08031 | Rear springs parabolic, Heavy Duty |
| 01372 | Rear springs air | | |

WHEELS AND TYRES

Front axle(s): 215/75R17.5; Driven rear axle(s): 215/75R17.5; Goodyear; Wheel protection rings silvergrey.

Optional

| | | | |
|-------|------------------------------|-------|----------------------|
| 06764 | Wheel protection rings black | 16152 | Tyre makes and types |
|-------|------------------------------|-------|----------------------|

DRIVELINE

Engine PX-4, 4 cylinder diesel engine, 3.8 litres. Output 115 kW (156 hp) at 2600 rpm. Max. torque 500 Nm at 1200-1900 rpm.; Exhaust emission Euro 6; Manual gearbox, 5 speeds; Gearbox ratio 5.76-0.77; Rear axle ratio 3.73.

Optional

| | |
|-------|--|
| 07383 | Engine PX-4, 127 kW/172 hp. Cab Badge: 170 |
|-------|--|

BRAKE SYSTEM

Exhaust brake.

CHASSIS

Wheelbase 4.30 m / rear overhang 2.32 m; Side member height 210 mm; EAS unit right, discharge right rearward; Plastic fuel tank 110 l; Tank for AdBlue® 25 l, right-hand side chassis; Spray suppression.

Optional

| | | | |
|-------|--------------------------------------|-------|-------------------------------------|
| 02001 | Plastic fuel tank 155 l | 07071 | Spare wheel carrier right-hand side |
| 02124 | Plastic fuel tank 185 l | | |
| 02011 | Spare wheel carrier in rear overhang | 03323 | Rear light with LEDs |

DRAWBAR AND TRAILER EQUIPMENT

Closing member.

BODIES AND PREPARATIONS FOR BODYING

Application connector chassis.

Optional

| | | | |
|-------|---|-------|--|
| 02597 | Application connector for tail lift control | 07487 | Body attachment BAM 1, loose consoles supply |
| 01503 | Side marker lights | 07488 | Body attachment BAM 3, loose consoles supply |

ELECTRICAL POWER SUPPLY

Alternator 80 A, batteries 2x 125 Ah..

Optional

| | | | |
|-------|------------------|-------|-------------------|
| 01897 | Alternator 100 A | 08797 | Batteries 2x175Ah |
|-------|------------------|-------|-------------------|

GVM AND GCM

Chassis weight related technical GVM max 7500 kg; Driveline related technical GCM equal to GVM.

APPLICATION CONDITIONS

Moisture separator, unheated; Air intake low.

Optional

| | | | |
|-------|----------------------------|-------|--------------------|
| 04767 | Moisture separator, heated | 04987 | Radiator flyscreen |
| 09960 | Air intake on the cab roof | | |

SERVICE AND MAINTENANCE

Standard Warranty takes care of 1 year complete vehicle, 2nd year driveline and 1st year breakdown.; ITS service.

VEHICLE DELIVERY

Standard toolkit.



Go to [DAF.com](https://www.daf.com) to configure your own perfect DAF.

LF 150

FA 4X2 Rigid, 08t City

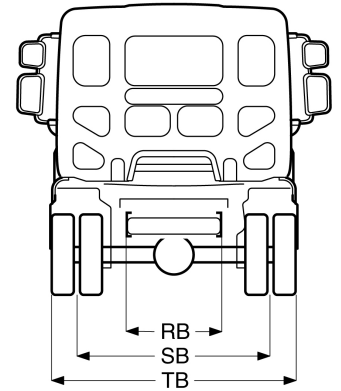
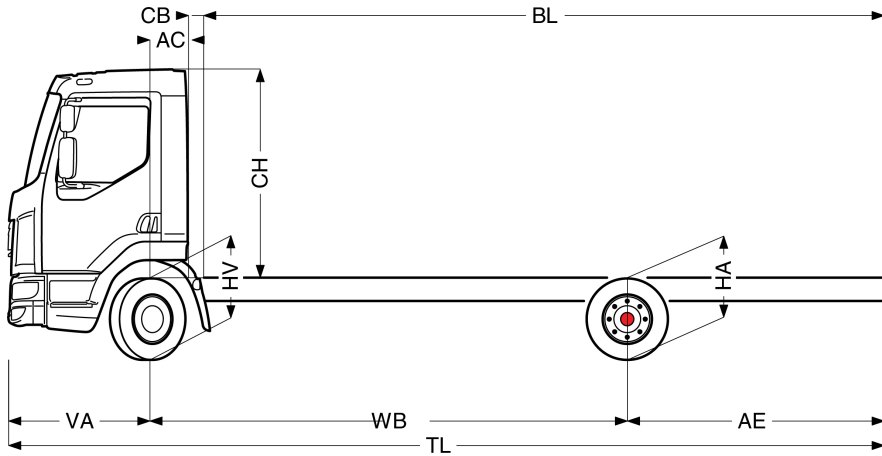

| | Wheelbase - AE | | Unladen weight ¹⁾ | | | Gross Carrying Capacity | | | Variable dimensions | | | | | | | | | |
|---------|----------------|------------------|------------------------------|------|-------|-------------------------|------|-------|---------------------|------------------|------------------|------------------|------|------|------------------|-------------------|-------------------|-------------------|
| | WB | AE ⁵⁾ | Front | Rear | Total | Front | Rear | Total | AC | CB ⁶⁾ | CH ⁷⁾ | BL ⁸⁾ | BL | TL | HA ⁹⁾ | HA ¹⁰⁾ | TK ¹¹⁾ | TW ¹²⁾ |
| DAY CAB | 3,05 | 1,80 | 2424 | 872 | 3296 | 1176 | 4128 | 4204 | 0,33 | 0,12 | 1,84 | 3,50 | 5,08 | 6,13 | 1,04 | 0,90 | 10,57 | 11,90 |
| | 3,15 | 1,62 | 2431 | 860 | 3291 | 1169 | 4140 | 4209 | 0,33 | 0,12 | 1,84 | 3,66 | 5,29 | 6,05 | 1,05 | 0,91 | 10,81 | 12,15 |
| | 3,55 | 1,87 | 2444 | 885 | 3329 | 1156 | 4115 | 4171 | 0,33 | 0,12 | 1,84 | 4,24 | 6,10 | 6,70 | 1,04 | 0,91 | 11,78 | 13,14 |
| | 3,90 | 2,12 | 2449 | 899 | 3347 | 1151 | 4101 | 4153 | 0,33 | 0,12 | 1,84 | 4,74 | 6,80 | 7,30 | 1,04 | 0,91 | 12,63 | 14,01 |
| | 4,30 | 2,32 | 2457 | 911 | 3369 | 1143 | 4089 | 4131 | 0,33 | 0,12 | 1,84 | 5,32 | 7,61 | 7,90 | 1,04 | 0,91 | 13,61 | 15,01 |
| | 4,65 | 2,65 | 2461 | 934 | 3395 | 1139 | 4066 | 4105 | 0,33 | 0,12 | 1,84 | 5,83 | 8,31 | 8,58 | 1,04 | 0,91 | 14,47 | 15,88 |
| | 5,00 | 2,72 | 2474 | 942 | 3415 | 1126 | 4058 | 4085 | 0,33 | 0,12 | 1,84 | 6,35 | 9,02 | 9,00 | 1,04 | 0,91 | 15,32 | 16,75 |

OTHER DIMENSIONS VA: 1,28 HV¹³⁾: 0,91 HV¹⁴⁾: 0,86 RB: 0,86 SB: 1,74 TB¹⁵⁾: 2,28

1) GVM in conformity with registration documents.
 2) GCM in conformity with registration documents.
 3) Axle load with standard tyre size.
 4) Chassis and cab weight calculated with: Standard specification items only with 110 litres of fuel, 25 litres of AdBlue® and driver of 90 kg, tolerance ± 3%. Changing of the specification can have major impact on vehicle weight.
 5) Other AE dimensions may be available for shown WB. Modify rear overhang to the calculated body length.
 6) CB is based on standard air intake and/or exhaust.
 7) Cab height is measured from frame member to closed cabin roof hatch.

8) Calculate customer specific body length with TOPEC. Body lengths shown based on evenly distributed load at max axle load.
 9) Unladen height at centre of driven axle(s).
 10) Laden height at centre of driven axle(s).
 11) TK = turning circle between kerbs.
 12) TW = turning circle between walls.
 13) Unladen height at centre of front axle(s).
 14) Laden height at centre of front axle(s).
 15) TB is overall width at rear. (At centre of front axle 255).

Depending on the vehicle configuration a specific option may not be possible. The availability and specification of this vehicle may differ per country. For further information please contact the DAF organisation. Pictures and technical illustrations are not binding in detail and can differ from the standard specification. Subject to modification without prior notice.