

Specification sheet

XD 220

FAN 6X2 Rigid, Electric



ENGINES

XD Electric 170 PACCAR EX-D1 (170 kW / 210 kWh 315 kWh 420 kWh 525 kWh)
XD Electric 220 PACCAR EX-D1 (220 kW / 315 kWh 420 kWh 525 kWh)
XD Electric 270 PACCAR EX-D1 (270 kW / 315 kWh 420 kWh 525 kWh)
XD Electric 270 PACCAR EX-D2 (270 kW / 315 kWh 420 kWh 525 kWh)
XD Electric 310 PACCAR EX-D2 (310kW / 420 kWh 525 kWh)
XD Electric 350 PACCAR EX-D2 (350kW / 420 kWh 525 kWh)

GVM¹⁾

26000 kg

Max. front 8000 kg

Max. rear 19000 kg

GCM²⁾

29000 kg

CAB EXTERIOR

Luxurious Day Cab with unrivalled aerodynamics for fuel efficient driving and low CO2 emissions. The huge and deep frontscreen, curved at the sides combined with large side windows offer an unsurpassed direct view for the driver, to enhance road safety. Cab length: 2030 mm; cab width: 2500 mm.; Cab suspension mechanical; LED head lights; DAF Corner View.

Optional

07018 Sleeper Cab	01836 LED Skylights
06244 Sleeper High Cab	00949 LED Skylights; aux. LED lights on cab rf, prepared
02889 Chassis front execution: no bottom plate	01925 Two LED work lamps for cab rear wall
02952 Chassis front execution: bottom plate aero	01891 Hazard beacons on cab front, prepared
03353 Chassis front execution: protruding	06629 Two hazard beacon lights
07586 Chassis front execution: robust	03232 Front windscreen with solar control foil
01226 Cab suspension air	03317 Rear window: double glass
03358 External sun visor	07343 Kerb view window co-driver door
03922 Fog lights front	01362 DAF Digital Vision System
00936 Auxiliary LED lights on cab roof, prepared	

AERODYNAMICS

Optional

00008 Adj. roof air deflector short Sleeper High Cab	00082 Adj. roof air deflector for Day Cab
00124 Adj. rf air defl.long mid >4m(!) Sleeper High Cab	00097 Adj. roof air deflector for Sleeper Cab
01538 Adj. roof air defl. long high >4m(!) Sleeper High	00020 Adj. roof air deflector long low Sleeper High Cab
02662 Adj. roof air defl. long mid XD Sleeper High Cab	

COLOURS

Cab colour E1980 Crystal White; Chassis colour grey.; Colour of bumper: Crystal White.

CAB INTERIOR

Cab interior trim colour: Luxury; Dashboard finish: Vision; Cab interior decoration: Hexagon; Driver seat: Comfort Air; Co-driver seat: cinema with fabric cover; No dashboard table; Storage compartment in centre; Automatic Temperature Control and airco; Auxiliary cab heater (water).

Optional

02354 Steering wheel with silver accents	02117 Third seat
02355 Steering wheel, leather	02837 Dashboard table
02353 Cab interior decoration: Argenta	03948 Single drawer
02350 Cab interior decoration: Natura	03954 Refrigerator
07733 Driver seat: Luxury Air	02838 Foam mattress for lower bunk
07736 Driver seat: Super Air	02854 Xtra Comfort mattress for lower bunk
07737 Driver seat: Xtra Leather Air	01775 Xtra Comfort mattress with topper for lower bunk
09541 Arm rest driver seat	06970 Automatic Cab Climate Control
01740 Arm rest at both sides of the driver seat	

COMMUNICATION AND DRIVING MANAGEMENT

PACCAR Connect; Tachograph digital, Stoneridge 1C version G2V2; Speed limiter setting 85/90 km/h; DAF Infotainment Luxury with Luxury speakers; Adaptive Cruise Control with FCW and AEBS-3; Driver Performance Assistant.

Optional

09681 Preparation for Maut	03470 DAF Infotainment System: Exclusive, prepared
06211 DAF Infotainment System with FM/DAB/DAB+ radio	01915 DAF Infotainment System: Luxury Plus

SAFETY AND SECURITY

Lane Departure Warning System; Vehicle Stability Control (VSC); Basic engine immobiliser system; No EC-ADR packages; DAF Side & Turn Assist.

Optional

08631 Air bag (driver) and 2 seat belt tensioners
--

SUSPENSION AND AXLES

Front: 8.00 t, parabolic, 163N; Rear axle load 13.00 t; Rear: 20.00 t, air suspension, SR1344; Trailing axle load 8.0t; Lifting device.

Optional

06257 Front axle load 9.00 t	04647 Front springs air
06095 Front axle load 10.00 t	08191 Axle load monitoring

WHEELS AND TYRES

Driven rear axle(s): 315/70R22.5; F1,315/70R22.5GO FMXSE 156/150 L Steering BBA 3P; R1,315/70R22.5GO FMXDE 154/150 L Traction BBA 3P; R2,315/70R22.5GO FMXSE 156/150 L Steering BBA 3P.

Optional

16152 Tyre makes and types

DRIVELINE

Electric motor type EX-D1; 220 kW; 150 kW DC charging; Battery Electric Vehicle; Rear axle ratio 2.38.

Optional

01656 Electric motor type EX-D2	01749 Charging: 150 kW DC + 22 kW AC
01664 170 kW	01756 325 kW DC charging
01686 270 kW	03677 Charging: 325 kW DC + 22 kW AC
01691 310 kW	01514 Urge-to-move
01692 350 kW	02843 Mechanical differential lock

BRAKE SYSTEM

Ventilated disc brakes front and rear. Dual circuit air system with electronic control (EBS). Electric driven, water cooled air compressor with automatic air heated dryer..

Optional

04901 Spring brake cylinders on the first front axle

CHASSIS

Wheelbase 4.60 m / rear overhang 2.55 m; Side member height 260 mm; Standard component location; 3 HV battery packs; HV battery pack left, position 2; HV battery pack right, position 2; Front underrun protection (FUP); Spray suppression.

Optional

02601 Side member height 310 mm	01626 No HV battery packs left
01699 4 HV battery packs	02296 HV battery pack right, position 3
01701 5 HV battery packs	01779 HV battery pack right, position 1
01634 HV battery pack left, position 1	01791 HV battery packs right, positions 1 and 2
02254 HV battery pack left, position 3	01799 HV battery packs right, positions 2 and 3
01759 HV battery packs left, positions 1 and 2	01658 No HV battery packs right
01762 HV battery packs left, positions 2 and 3	16157 Fuel tanks, material and sizes

DRAWBAR AND TRAILER EQUIPMENT

Closing member D-value = 0kN.

Optional

07033 Trailer coupling Ringfeder D=13.7	08027 Trailer coupling Rockinger D=20.0
07034 Trailer coupling Ringfeder D=20.0	04659 Trailer cable EBS
08026 Trailer coupling Rockinger D=13.0	

BODIES AND PREPARATIONS FOR BODYING

Application connector chassis.

Optional

09421 Additional spare wiring	09201 Chassis preparation for BDF
02950 Application connector for hydraulic platform	08121 Tail lift application

POWER TAKE-OFF (PTO)

Optional

01809 E-PTO socket 650V DC < 25 kW	04320 E-PTO socket 650V DC < 90 kW
---	---

24V POWER SUPPLY

Batteries 2x 175 Ah..

Optional

07671 Batteries 2x210Ah AGM C-type	06440 Batteries 2x230Ah
---	--------------------------------

GVM AND GCM

Chassis weight related technical GVM max 27000 kg; Driveline related max GCM 29000 kg.

Optional

01933 Driveline related max GCM 42000 kg	02200 Driveline related max GCM 46000 kg class 2
01937 Driveline related max GCM 46000 kg	03675 Driveline related max GCM 50000 kg class 3

APPLICATION CONDITIONS

Optional

02260 Extra cab insulation	06614 Anti-dust blow-up shield
-----------------------------------	---------------------------------------

SERVICE AND MAINTENANCE

Standard Warranty takes care of 1 year complete vehicle as supplied by the OEM (excl. real wear parts), 2nd year driveline and 1st year breakdown.; ITS service.

VEHICLE DELIVERY

Minimum toolkit.

Optional

07569 Lifting jack

OPTION PACKAGES

Optional

17448 Safety pack	17595 Executive Pack XD/XF
--------------------------	-----------------------------------

Go to [DAF.com](https://www.daf.com) to configure your own perfect DAF.

XD 220

FAN 6X2 Rigid, Electric

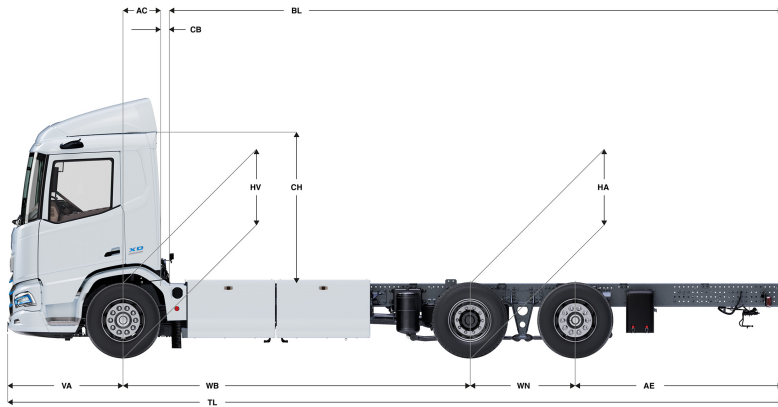

	Wheelbase - AE		Unladen weight ¹⁾			Gross Carrying Capacity			Variable dimensions									
	WB	AE ⁵⁾	Front	Rear	Total	Front	Rear	Total	AC	CB ⁶⁾	CH	BL ⁷⁾	BL	TL	HA ⁸⁾	HA ⁹⁾	TK ¹⁰⁾	TW ¹¹⁾
DAY CAB	3,80	2,05	6302	3550	9852	1698	15450	16148	0,50	0,07	2,06	6,69	6,69	8,78	0,97	0,94	13,50	14,88
	3,90	2,50	5747	4407	10154	2253	14593	15846	0,50	0,07	2,01	5,59	5,59	7,93	1,02	0,97	13,75	15,14
	4,00	2,40	6342	3645	9987	1658	15355	16013	0,50	0,07	2,01	7,06	7,06	9,33	1,02	0,99	14,01	15,41
	4,20	2,40	5937	4086	10022	2063	14914	15978	0,50	0,07	2,06	7,18	7,18	9,53	0,97	0,94	14,53	15,94
	4,40	2,55	6006	4141	10147	1994	14859	15853	0,50	0,07	2,06	7,57	7,57	9,88	0,97	0,94	15,05	16,46
	4,60	2,55	6064	4092	10156	1936	14908	15844	0,50	0,07	2,06	7,96	7,96	10,08	0,97	0,94	15,57	16,99
	4,80	2,70	6111	4103	10214	1889	14897	15786	0,50	0,07	2,06	8,34	8,34	10,43	0,97	0,94	16,09	17,52
	5,05	2,90	6151	4076	10227	1849	14924	15773	0,50	0,07	2,06	8,81	8,81	10,88	0,97	0,94	16,74	18,18
	5,30	3,15	6181	4061	10242	1819	14939	15758	0,50	0,07	2,06	9,27	9,27	11,38	0,97	0,94	17,39	18,84
5,60	3,15	7015	4313	11328	985	14687	14672	0,50	0,07	2,01	10,38	10,38	11,68	1,02	1,00	18,18	19,63	
6,10	2,90	7156	4247	11402	844	14753	14598	0,50	0,07	2,01	11,43	11,43	11,93	1,02	1,00	19,49	20,96	
SLEEPER CAB	WB	AE ⁵⁾	Front	Rear	Total	Front	Rear	Total	AC	CB ⁶⁾	CH	BL ⁷⁾	BL	TL	HA ⁸⁾	HA ⁹⁾	TK ¹⁰⁾	TW ¹¹⁾
	4,20	2,40	6043	4088	10132	1957	14912	15868	0,83	0,07	2,06	6,58	6,58	9,53	0,97	0,94	14,53	15,94
	4,40	2,55	6113	4143	10256	1887	14857	15744	0,83	0,07	2,06	6,97	6,97	9,88	0,97	0,94	15,05	16,46
	4,60	2,55	6170	4095	10265	1830	14905	15735	0,83	0,07	2,06	7,35	7,35	10,08	0,97	0,94	15,57	16,99
	4,80	2,70	6218	4105	10323	1782	14895	15677	0,83	0,07	2,06	7,74	7,74	10,43	0,97	0,94	16,09	17,52
	5,05	2,90	6258	4079	10336	1742	14921	15664	0,83	0,07	2,06	8,20	8,20	10,88	0,97	0,94	16,74	18,18
	5,30	3,15	6288	4064	10351	1712	14936	15649	0,83	0,07	2,06	8,67	8,67	11,38	0,97	0,94	17,39	18,84
5,60	3,15	7119	4315	11434	881	14685	14566	0,83	0,07	2,01	9,80	9,80	11,68	1,02	1,00	18,18	19,63	
6,10	2,90	7260	4248	11508	740	14752	14492	0,83	0,07	2,01	10,86	10,86	11,93	1,02	1,00	19,49	20,96	
SLEEPER HIGH CAB	WB	AE ⁵⁾	Front	Rear	Total	Front	Rear	Total	AC	CB ⁶⁾	CH	BL ⁷⁾	BL	TL	HA ⁸⁾	HA ⁹⁾	TK ¹⁰⁾	TW ¹¹⁾
	4,20	2,40	6074	4088	10161	1926	14912	15839	0,83	0,07	2,54	6,60	6,60	9,53	0,97	0,94	14,53	15,94
	4,40	2,55	6143	4143	10286	1857	14857	15714	0,83	0,07	2,54	6,98	6,98	9,88	0,97	0,94	15,05	16,46
	4,60	2,55	6201	4094	10295	1799	14906	15705	0,83	0,07	2,54	7,38	7,38	10,08	0,97	0,94	15,57	16,99
	4,80	2,70	6248	4105	10353	1752	14895	15647	0,83	0,07	2,54	7,75	7,75	10,43	0,97	0,94	16,09	17,52
	5,05	2,90	6288	4078	10366	1712	14922	15634	0,83	0,07	2,54	8,24	8,24	10,88	0,97	0,94	16,74	18,18
	5,30	3,15	6318	4063	10381	1682	14937	15619	0,83	0,07	2,54	8,69	8,69	11,38	0,97	0,94	17,39	18,84
5,60	3,15	7149	4314	11464	851	14686	14536	0,83	0,07	2,49	9,81	9,81	11,68	1,02	1,00	18,18	19,63	
6,10	2,90	7290	4247	11538	710	14753	14462	0,83	0,07	2,49	10,88	10,88	11,93	1,02	1,00	19,49	20,96	

OTHER DIMENSIONS VA: 1,53 WN: 1,40 HV¹²⁾: 0,94 HV¹³⁾: 0,89 RB: 0,79 SB: 1,82 TB¹⁴⁾: 2,48

1) GVM in conformity with registration documents.
 2) GCM in conformity with registration documents.
 3) Axle load with standard tyre size.
 4) Chassis and cab weight calculated with: Standard specification items only with driver of (0) kg, tolerance ± 3%. Changing of the specification can have major impact on vehicle weight
 5) Other AE dimensions may be available for shown WB. Modify rear overhang to the calculated body length.
 6) CB is based on standard air intake and/or exhaust.
 7) Calculate customer specific body length with TOPEC. Body lengths shown based on evenly distributed load at max axle load.

8) Unladen height at centre of driven axle (trailing axle down).
 9) Laden height at centre of driven axle(s).
 10) TK = turning circle between kerbs.
 11) TW = turning circle between walls.
 12) Unladen height at centre of front axle(s).
 13) Laden height at centre of front axle(s).
 14) TB is overall width at rear. (At centre of front axle 255).

Depending on the vehicle configuration a specific option may not be possible. The availability and specification of this vehicle may differ per country. For further information please contact the DAF organisation. Pictures and technical illustrations are not binding in detail and can differ from the standard specification. Subject to modification without prior notice.