

Specification sheet

XD 300

FAT 6X4 Rigid



ENGINES

XD NewGen 300 MX-11 (220 kW / 299 hp)
XD NewGen 340 MX-11 (251 kW / 341 hp)
XD NewGen 370 MX-11 (270 kW / 367 hp)
XD NewGen 410 MX-11 (300 kW / 408 hp)
XD NewGen 450 MX-11 (330 kW / 449 hp)

GVM¹⁾

26000 kg
Max. front 8000 kg
Max. rear 19000 kg

GCM²⁾

32000 kg

OPTION PACKAGES

Optional

17448 Safety pack **17595** Executive Pack XD/XF

CAB EXTERIOR

Luxurious Day Cab with unrivalled aerodynamics for fuel efficient driving and low CO2 emissions. The huge and deep frontscreen, curved at the sides combined with large side windows offer an unsurpassed direct view for the driver, to enhance road safety. Cab length: 2030 mm; cab width: 2500 mm. Number of cab entrance steps: 2.; Cab suspension mechanical; LED head lights; DAF Corner View.

Optional

07018 Sleeper Cab	01836 LED Skylights
06244 Sleeper High Cab	00949 LED Skylights; aux. LED lights on cab rf, prepared
02889 Chassis front execution: no bottom plate	01925 Two LED work lamps for cab rear wall
02952 Chassis front execution: bottom plate aero	01891 Hazard beacons on cab front, prepared
03353 Chassis front execution: protruding	06629 Two hazard beacon lights
07586 Chassis front execution: robust	03232 Front windscreen with solar control foil
01226 Cab suspension air	03317 Rear window: double glass
03358 External sun visor	07343 Kerb view window co-driver door
03922 Fog lights front	01362 DAF Digital Vision System
00936 Auxiliary LED lights on cab roof, prepared	

AERODYNAMICS

Optional

00008 Adj. roof air deflector short Sleeper High Cab	00082 Adj. roof air deflector for Day Cab
00124 Adj. rf air defl.long mid >4m(!) Sleeper High Cab	00097 Adj. roof air deflector for Sleeper Cab
01538 Adj. roof air defl. long high >4m(!) Sleeper High	00020 Adj. roof air deflector long low Sleeper High Cab
02662 Adj. roof air defl. long mid XD Sleeper High Cab	

COLOURS

Cab colour E1980 Crystal White; Chassis colour grey.; Colour of bumper: Crystal White.

CAB INTERIOR

Cab interior trim colour: Luxury; Dashboard finish: Vision; Cab interior decoration: Hexagon; Driver seat: Comfort Air; Co-driver seat: cinema with fabric cover; No dashboard table; Storage compartment in centre; Automatic Temperature Control and aircoc; No auxiliary cab heater.

Optional

02354 Steering wheel with silver accents	02117 Third seat
02355 Steering wheel, leather	02837 Dashboard table
02353 Cab interior decoration: Argenta	03948 Single drawer
02350 Cab interior decoration: Natura	03954 Refrigerator
07733 Driver seat: Luxury Air	02838 Foam mattress for lower bunk
07736 Driver seat: Super Air	02854 Xtra Comfort mattress for lower bunk
07737 Driver seat: Xtra Leather Air	01775 Xtra Comfort mattress with topper for lower bunk
09541 Arm rest driver seat	06970 Automatic Cab Climate Control
01740 Arm rest at both sides of the driver seat	

COMMUNICATION AND DRIVING MANAGEMENT

PACCAR Connect; Tachograph digital, Stoneridge 1C version G2V2; Speed limiter setting 85/90 km/h; DAF Infotainment Luxury with Luxury speakers; Adaptive Cruise Control with FCW and AEBS-3; Driver Performance Assistant.

Optional

09681 Preparation for Maut	01915 DAF Infotainment System: Luxury Plus
06211 DAF Infotainment System with FM/DAB/DAB+ radio	06991 Predictive Cruise Control
03470 DAF Infotainment System: Exclusive, prepared	

SAFETY AND SECURITY

Lane Departure Warning System; Vehicle Stability Control (VSC); Basic engine immobiliser system; No EC-ADR packages; DAF Side & Turn Assist.

Optional

08631 Air bag (driver) and 2 seat belt tensioners	00795 Safety regulations EC ADR
06410 Safe Load Pass preparation	

SUSPENSION AND AXLES

Front: 8.00 t, parabolic, 163N; Rear axle load 9.50+ 9.50 t; Rear: 19.00 t, trapezium, SR1132T; No lifting device.

Optional

01769 Front axle load 7.50 t	01372 Rear springs air
06257 Front axle load 9.00 t	04549 Rear axle load 10.50+ 10.50 t
07494 Rear axle HR1670T	04563 Rear axle load 13.00+ 13.00 t
02788 Rear axle SR1360T	08191 Axle load monitoring

WHEELS AND TYRES

Driven rear axle(s): 315/70R22.5; F1,315/70R22.5GO FMXSE 156/150 L Steering BBA 3P; R1,315/70R22.5GO FMXDE 154/150 L Traction BBA 3P.

Optional

16152 Tyre makes and types

DRIVELINE

Engine MX-11, multi torque 6 cylinder diesel engine, 10.8 litres. Output 220 kW (299 hp) at 1600 rpm. Max. torque 1450 Nm at 900-1400 rpm.; Exhaust emission Euro 6; Eco fuel; 12-speed TraXon 12TX1810 OD, 12.92-0.77; Gearbox ratio 12.92-0.77; Rear axle ratio 3.73.

Optional

07110 Eco performance	09638 Off-road applications
02313 Gearbox direct drive	01498 Off-road applications with Rock-free function
01514 Urge-to-move	08370 Refuse collection
09637 Liquid transport	

BRAKE SYSTEM

Exhaust brake; Ventilated disc brakes at front, rear tandem axle with drum brakes. Dual circuit air system with electronic control (EBS)..

Optional

09921 MX Engine Brake	01497 Park brake control pneumatic with spoken warning
02715 ZF Intarder	06127 Driven rear axle with disc brakes
01572 Park brake control electro-pneumatic	

CHASSIS

Wheelbase 4.55 m / rear overhang 1.65 m; Side member height 310 mm; Standard component location; 340 l alu fuel tank LH, height 620 mm; Tank for AdBlue® 45 l, left-hand side chassis; Front underrun protection (FUP); Spray suppression.

Optional

- 16157** Fuel tanks, material and sizes
07070 Spare wheel carrier left-hand side
03323 Rear light with LEDs

DRAWBAR AND TRAILER EQUIPMENT

Closing member.

Optional

- 07033** Trailer coupling Ringfeder D=13.7
07034 Trailer coupling Ringfeder D=20.0
08026 Trailer coupling Rockinger D=13.0
08027 Trailer coupling Rockinger D=20.0
04659 Trailer cable EBS

BODIES AND PREPARATIONS FOR BODYING

Application connector chassis.

Optional

- 09421** Additional spare wiring
09240 Application connector for refuse collector

POWER TAKE-OFF (PTO)

Optional

- 16148** PTO types and positions

24V POWER SUPPLY

Alternator 110 A, batteries 2x 140 Ah..

Optional

- 04492** Alternator 130 A
08775 Alternator 150 A
08797 Batteries 2x175Ah
07671 Batteries 2x210Ah AGM C-type
06440 Batteries 2x230Ah

GVM AND GCM

Chassis weight related technical GVM max 26000 kg; Driveline related max GCM 32000 kg class 2.

Optional

- 03027** Driveline related max GCM 32000 kg class 3
01207 Driveline related max GCM 35500 kg class 2
01208 Driveline related max GCM 35500 kg class 3
00200 Driveline related max GCM 38000 kg class 2
00209 Driveline related max GCM 40000 kg class 3
03673 Driveline related max GCM 44000 kg class 2
03675 Driveline related max GCM 50000 kg class 3
00778 Driveline related max GCM 58000 kg class 2
07279 Driveline related max GCM 60000 kg class 2
00818 Driveline related max GCM 60000 kg class 3
00157 Driveline related max GCM 61000 kg class 2

APPLICATION CONDITIONS

Air intake front.

Optional

- 02260** Extra cab insulation
03648 Cyclonic air intake high
06614 Anti-dust blow-up shield

SERVICE AND MAINTENANCE

Standard Warranty takes care of 1 year complete vehicle as supplied by the OEM (excl. real wear parts), 2nd year driveline and 1st year breakdown.; ITS service.

Optional

- 08311** Service interval extended

VEHICLE DELIVERY

Minimum toolkit.

Optional

- 07569** Lifting jack



Go to [DAF.com](https://www.daf.com) to configure your own perfect DAF.

XD 300

FAT 6X4 Rigid

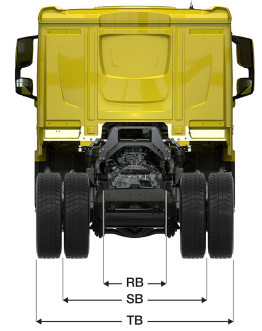
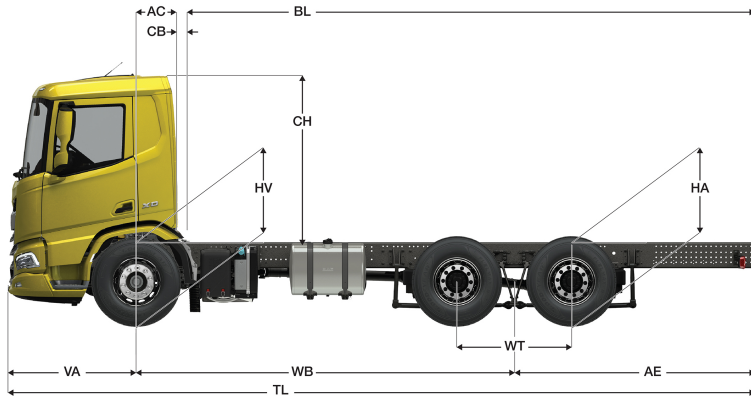

	Wheelbase - AE		Unladen weight ¹⁾			Gross Carrying Capacity			Variable dimensions									
	WB	AE ⁵⁾	Front	Rear	Total	Front	Rear	Total	AC	CB ⁶⁾	CH	BL ⁷⁾	BL	TL	HA ⁸⁾	HA ⁹⁾	TK ¹⁰⁾	TW ¹¹⁾
DAY CAB	4,05	1,65	4912	3984	8896	3088	15016	17104	0,50	0,07	2,01	5,56	5,56	7,23	1,13	1,09	14,14	15,54
	4,55	1,65	4831	3608	8439	3169	15392	17561	0,50	0,07	2,01	6,32	6,41	7,73	1,15	1,10	15,44	16,86
	5,00	1,65	4961	4095	9056	3039	14905	16944	0,50	0,07	2,01	7,13	7,13	8,18	1,13	1,09	16,61	18,05
	5,55	3,20	4991	4543	9534	3009	14457	16466	0,50	0,07	2,01	8,01	8,01	10,28	1,13	1,08	18,05	19,50
SLEEPER CAB	4,05	1,65	5016	3987	9003	2984	15013	16997	0,83	0,07	2,01	4,93	4,93	7,23	1,13	1,08	14,14	15,54
	4,55	1,65	4935	3611	8546	3065	15389	17454	0,83	0,07	2,01	5,71	5,80	7,73	1,15	1,09	15,44	16,86
	5,00	1,65	5065	4097	9162	2935	14903	16838	0,83	0,07	2,01	6,53	6,53	8,18	1,13	1,09	16,61	18,05
	5,55	3,20	5095	4545	9641	2905	14455	16359	0,83	0,07	2,01	7,40	7,40	10,28	1,13	1,08	18,05	19,50
SLEEPER HIGH CAB	4,05	1,65	5047	3985	9032	2953	15015	16968	0,83	0,07	2,49	4,94	4,94	7,23	1,13	1,08	14,14	15,54
	4,55	1,65	4966	3610	8576	3034	15390	17424	0,83	0,07	2,49	5,72	5,81	7,73	1,15	1,09	15,44	16,86
	5,00	1,65	5096	4096	9192	2904	14904	16808	0,83	0,07	2,49	6,54	6,54	8,18	1,13	1,09	16,61	18,05
	5,55	3,20	5126	4545	9670	2874	14455	16330	0,83	0,07	2,49	7,42	7,42	10,28	1,13	1,08	18,05	19,50

OTHER DIMENSIONS	VA: 1,53	WT: 1,40	HV ¹²⁾ : 1,02	HV ¹³⁾ : 0,92	RB: 0,79	SB: 1,82	TB ¹⁴⁾ : 2,48
------------------	----------	----------	--------------------------	--------------------------	----------	----------	--------------------------

- GVM in conformity with registration documents.
- GCM in conformity with registration documents.
- Axle load with standard tyre size.
- Chassis and cab weight calculated with: Standard specification items only with 340 litres of fuel, 45 litres of AdBlue® and driver of 90 kg, tolerance ± 3%. Changing of the specification can have major impact on vehicle weight.
- Other AE dimensions may be available for shown WB. Modify rear overhang to the calculated body length.
- CB is based on standard air intake and/or exhaust.
- Calculate customer specific body length with TOPEC. Body lengths shown based on evenly distributed load at max axle load.

- Unladen height at centre of driven axle(s).
- Laden height at centre of driven axle(s).
- Axle load with standard tyre size.
- TW = turning circle between kerbs.
- TW = turning circle between walls.
- Unladen height at centre of front axle(s).
- Laden height at centre of front axle(s).
- TB is overall width at rear. (At centre of front axle 255).

Depending on the vehicle configuration a specific option may not be possible. The availability and specification of this vehicle may differ per country. For further information please contact the DAF organisation. Pictures and technical illustrations are not binding in detail and can differ from the standard specification. Subject to modification without prior notice.